

LIBERTY

**Requirements For
Electric Service And Meter Installations**

Residential



Liberty™

(800) 206 – 2300

The latest revision of this book can be found on-line at:

<https://central.libertyutilities.com/all/residential/new-service/service-standards.html>

Select "Residential Service Standards 2021".

Effective 3/24/2021 (REV0)

Some of the information in this booklet is based on governmental codes and ordinances as well as the National Electrical Code and the tariffs of Liberty on file with the Public Service Commissions. These requirements and guidelines are issued with the intent of complying with all applicable codes, ordinances and tariffs; however, in the case of conflict, the appropriate code, ordinance and tariff will supersede the interpretation offered in this booklet. In addition, these requirements are subject to change in the event that the governing codes, ordinances and tariffs are changed. Liberty does not assume responsibility for keeping this book current and should be consulted in case of doubt on the applicability of any terms.

When the term "contact the Company" is used in this booklet, it shall mean for each and every installation, not a single contact.

This publication includes a number of changes and supersedes all previous editions.

THIS PAGE INTENTIONALLY LEFT BLANK

TABLE OF CONTENTS

1.0 INTRODUCTION	1
2.0 GENERAL INFORMATION	2
2.1 DEFINITIONS	2
2.2 AVAILABILITY AND LOCATION OF SERVICE	7
2.3 TYPE AND CHARACTER OF SERVICE.....	7
2.4 GENERAL REQUIREMENTS.....	8
2.5 ALTERATIONS AND ADDITIONS	8
3.0 METERING.....	9
3.1 GROUNDING.....	9
3.2 METERING EQUIPMENT LOCATIONS.....	9
4.0 INFORMATION APPLYING TO ALL SERVICES	10
5.0 TEMPORARY SERVICES	11
6.0 OVERHEAD SERVICES	16
6.1 GENERAL INFORMATION	16
6.2 100 AMP, 200 AMP, AND 320 AMP SINGLE PHASE OVERHEAD SERVICES.....	18
6.3 MULTIPLE METERS, SINGLE PHASE OVERHEAD SERVICE.....	34
7.0 UNDERGROUND SERVICES.....	38
7.1 GENERAL INFORMATION	38
7.2 200 AMP AND 320 AMP SINGLE PHASE UNDERGROUND SERVICE	42
7.3 600 AMP TO 800 AMP CT METERING, SINGLE PHASE UNDERGROUND SERVICE.....	54
7.4 MULTIPLE METERS, SINGLE PHASE UNDERGROUND SERVICE	58
Appendix A	64
Appendix B	72

TABLE OF FIGURES

FIGURE 1: DEFINITIONS	4
FIGURE 2: DEFINITIONS	5
FIGURE 3: DEFINITIONS	6
FIGURE 4: TEMPORARY SERVICE FROM OVERHEAD FACILITIES	12
FIGURE 5: TEMPORARY SERVICE FROM UNDERGROUND FACILITIES	13
FIGURE 6: TEMPORARY SERVICE FROM UNDERGROUND FACILITIES (CONTINUED)	14
FIGURE 7: (FUTURE USE).....	15
FIGURE 8: 100/200/320 AMP OVERHEAD SERVICE.....	20
FIGURE 9: 100/200/320 AMP STEEL SERVICE MAST	21
FIGURE 10: 100/200 AMP METER SOCKET, OVERHEAD SERVICE	22
FIGURE 11: 100/200 AMP METER SOCKET, NETWORK (120/208), OVERHEAD SERVICE	23
FIGURE 12: 100/200 AMP COMBINATION METER SOCKET	24
FIGURE 13: 100/200 AMP COMBINATION METER SOCKET, NETWORK (120/208), OVERHEAD SERVICE	25
FIGURE 14: 320 AMP METER SOCKET, OVERHEAD SERVICE	26
FIGURE 14A: 320 AMP METER SOCKET, NETWORK (120/208), OVERHEAD SERVICE	27
FIGURE 15: 320 AMP COMBINATION METER SOCKET, OVERHEAD SERVICE	28
FIGURE 15A: 320 AMP COMBINATION METER SOCKET, NETWORK (120/208), OVERHEAD SERVICE	29
FIGURE 16: 100/200 AMP METER POLE, UNDERGROUND FEEDER.....	30
FIGURE 17: 100/200 AMP METER POLE, OVERHEAD FEEDER	31
FIGURE 18: 320 AMP METER POLE, UNDERGROUND FEEDER.....	32
FIGURE 19: 320 AMP METER POLE, OVERHEAD FEEDER	33
FIGURE 20: WIRING OF TWO METERS, OVERHEAD SERVICE.....	36
FIGURE 21: THREE TO SIX METERS, OVERHEAD SERVICE.....	37
FIGURE 22: UNDERGROUND SERVICE DETAIL	39
FIGURE 23: UNDERGROUND SERVICE DETAIL (CONTINUED)	40
FIGURE 24: UNDERGROUND SERVICE STRUCTURE	41
FIGURE 25: 200/320 AMP UNDERGROUND SERVICE	44
FIGURE 26: 200 AMP METER SOCKET, UNDERGROUND SERVICE.....	45
FIGURE 27: 200 AMP METER SOCKET, NETWORK (120/208), UNDERGROUND SERVICE	46
FIGURE 28: 200 AMP COMBINATION METER SOCKET, UNDERGROUND SERVICE.....	47
FIGURE 29: 200 AMP COMBINATION METER SOCKET, NETWORK (120/208), UNDERGROUND SERVICE ..	48
FIGURE 30: 320 AMP METER SOCKET, UNDERGROUND SERVICE.....	49
FIGURE 30A: 320 AMP METER SOCKET, NETWORK (120/208), UNDERGROUND SERVICE.....	50
FIGURE 31: 320 AMP COMBINATION METER SOCKET, UNDERGROUND SERVICE.....	51
FIGURE 31A: 320 AMP COMBINATION METER SOCKET, NETWORK (120/208), UNDERGROUND SERVICE	52
FIGURE 32: METER PEDESTAL	53
FIGURE 33: 600 AMP TO 800 AMP CURRENT TRANSFORMER METERING, UNDERGROUND SERVICE	57
FIGURE 34: WIRING OF TWO METERS, UNDERGROUND SERVICE	60
FIGURE 35: THREE TO SIX METERS, UNDERGROUND SERVICE	61
FIGURE 36: SEVEN OR MORE METERS, UNDERGROUND SERVICE.....	63

1.0 INTRODUCTION

Liberty constantly strives to maintain a high standard of service to all Customers. This booklet has been prepared for use by Customers, architects, engineers, electrical contractors and local inspecting authorities so they may receive full benefit from our service. We believe you will find it helpful when planning new electrical installations, upgrading, or adding additional equipment. Copies are available at the Liberty Central Region Corporate office, service centers, and on-line through the web site; www.empiredistrict.com. All holders of Requirements for Electric Service and Meter Installations booklets are encouraged to submit comments to aid in future revisions. Please submit comments as follows:

1. Give section, paragraph and page number to which the comment pertains.
2. Submit comments in writing; giving details, sketches, drawings, and all supporting pertinent information.
3. Mail or Email to:

LIBERTY
Standards Engineering
PO Box 127
Joplin MO 64802
Email: Jeff.Brown@libertyutilities.com

The impression generally prevails that compliance with the National Electrical Code (NEC), or the various electrical ordinances guarantees to the Customer a wiring installation complete and adequate for the full use of electric service now and in the future. This is not necessarily the case. The NEC and these guidelines are designed to provide the minimum requirements considered necessary for safety. **(The NEC, Article 90.1 B itself states, "Compliance therewith and proper maintenance will result in an installation that is essentially free from hazard, but not necessarily efficient, convenient, or adequate for good service or future expansion of electrical use.")** Careful design and installation often results in a wiring system that exceeds NEC requirements.

LIBERTY, as a utility, must meet the requirements of the National Electrical Safety Code (NESC), which sometimes differ from the National Electrical Code (NEC).

The Company shall have the right to disconnect or refuse service to any installation which violates local, municipal, NEC or NESC regulations. The Company shall also have the right to disconnect or refuse service for installations that are hazardous to the public, or negatively impacts service to other Customers, or Company facilities.

Except for the installation and maintenance of its own property, Liberty does not install or repair wiring or equipment beyond the point of delivery. Therefore, Liberty is not responsible for the voltage levels beyond the point of delivery and does not assume any responsibility for Customer facilities beyond the point of delivery. Your cooperation will be greatly appreciated and will enable you to receive prompt and satisfactory service.

2.0 GENERAL INFORMATION

2.1 DEFINITIONS

Company	LIBERTY
Conduit	Pipe used to protect the electrical conductors. Rigid Steel or Schedule 80 Electrical Grade PVC is required on the wall when an underground service is provided.
Conduit Strap	A properly sized strap or clamp used with screws or nails to securely attach conduit to the structure.
Conduit Reducer	A fitting that provides a way to connect together different sized conduits.
Conduit Vent	A fitting used to provide an outlet so that gases or fluids can be released externally from the conduit. This is commonly used in hilly terrain.
Contribution-in-Aid Construction	An amount to be paid to the Company by a Customer or developer when of the Company has to install electrical facilities over and above what is normally required to provide service. This is required when the cost to serve is not justified by the expected revenue provided by the service.
Customer	User of the Company's electric service or user's authorized representative (architect, engineer, electrical contractor, etc.).
Drip Loop	Short length of the customer's service entrance conductors (wire) extending out of the weatherhead which allows connection to the Company's service drop.
Inspector or Inspection Authority	A person or agency authorized by a governmental body to inspect and approve electrical installations.
Interconnection-Cogeneration and Small Power Producers	An electric service where co-generators and small power producers operate in parallel with the Company's electric system. Energy may flow in either direction through an interconnection.
Intersystem Ground Connector (Intersystem Bonding Termination)	A device that provides a means for connecting communication system(s) grounding conductor(s) and bonding conductor(s) at the service equipment or at the disconnecting means for buildings or structures supplied by a feeder or branch circuit.
Line of Sight	Is a straight line from the Liberty designated service source, i.e. Service Pole, Transformer Pole, Pad Mounted Transformer, Secondary Pedestal, etc. to the Liberty Point of Delivery. (See Figure 3)
Main Disconnect	This term as used in this document refers to a combination of a disconnecting and overcurrent protection device, e.g. fuse and manual switch or circuit breaker. Liberty recommends that a circuit breaker be used to accomplish this function.
Manufactured Home/Building	Shall be defined by the following requirements: <ul style="list-style-type: none">A. The structure shall be installed on and secured to a permanent foundation. This does not mean block piers with cable or strap tie downs.B. The structural integrity of the manufactured home is sufficient to support the metered service equipment per NEC 550.32.
Meter Loop	Customer provided wire and enclosure connecting the Customer's service equipment to the Company's service drop. Consists of the following: Point of Attachment, wires, weatherhead, conduit, conduit straps, and meter socket/disconnect combination. These can be separate components.
Mobile Home	Shall be defined as any other type of structure moved to a site that does not match the Manufactured Building definition of this document.
NEC	The latest edition of the National Electrical Code.
NESC	The latest edition of the National Electrical Safety Code.

Point of Attachment	The point <i>designated by the Company</i> at which the Company's service drop is attached to the Customer's facility. Can be attached to the structure or to rigid steel conduit. It must be capable of withstanding a 200 pound continuous pull in the direction of the service drop and be electrically insulated from the structure.
Point of Delivery	The point <i>designated by the Company</i> where the Company's facilities terminate at the Customer's facilities.
Readily Accessible	Capable of being reached quickly, for operation, renewal, or inspections without requiring those to whom ready access is a requisite to climb over or remove obstacles or resort to portable ladders, etc.
Self-Contained Meter Socket	A meter socket that is installed in line with the service entrance or lateral conductors. If the socket were replaced with conductor, the power could flow straight through to the service equipment.
Service	The supply by the Company of electricity to the Customer, including the readiness and availability of electrical energy at the point of delivery, at the standard available voltage whether or not utilized by the Customer.
Service Drop	The overhead service conductors between Company's last pole or other aerial support to and including the connectors to the service entrance conductors at the point of delivery to the Customer's property.
Service Entrance	Customer owned conductors and enclosures connecting the Customer's service equipment to the Company's service drop or service lateral.
Slip Joint	A fitting that provides a slip fit adjustment of PVC conduit extending from an electric service box on a building to an underground electric service line. The fitting allows for subsidence of the ground level without creating excessive force on the service box.
Service Lateral	The underground service conductors between the Company's secondary pedestal or transformer, including any risers at a pole or other structure and the point of delivery.
Sweep Elbow or ELL	Conduit Bend.
Undisturbed Earth	Soil that has not been moved by construction or re-compacted soil that approximates such. In engineering terms, it is top soil or clay void of rotting debris that has been re-compacted in 1 foot lifts to the desired level using a vibrating roller or sheeps-foot roller and achieving a 95% modified Proctor Density at each lift.
Wire Size	This refers to the AWG (American Wire Gauge) designation of copper wire unless otherwise specified. Should another approved conductor material be used, a size having the equivalent current carrying capacity shall be selected.

DEFINITIONS ONLY

REFER TO INSTALLATION SPECIFICATION AND FIGURES FOR CONSTRUCTION DETAILS.

Meter Loop - Customer provided wire and enclosure connecting the customer's service equipment to the Company's service drop. Consists of the following: **Point of Attachment, wires, weatherhead, conduit, conduit straps, and meter socket.**

Point of Attachment - The point as *designated by the Company* at which the Company's service drop is attached to the Customer's facility. Can be attached to the structure or to rigid steel conduit. It must be capable of withstanding a 200 pound continuous pull in the direction of the service drop and be electrically insulated from the structure.

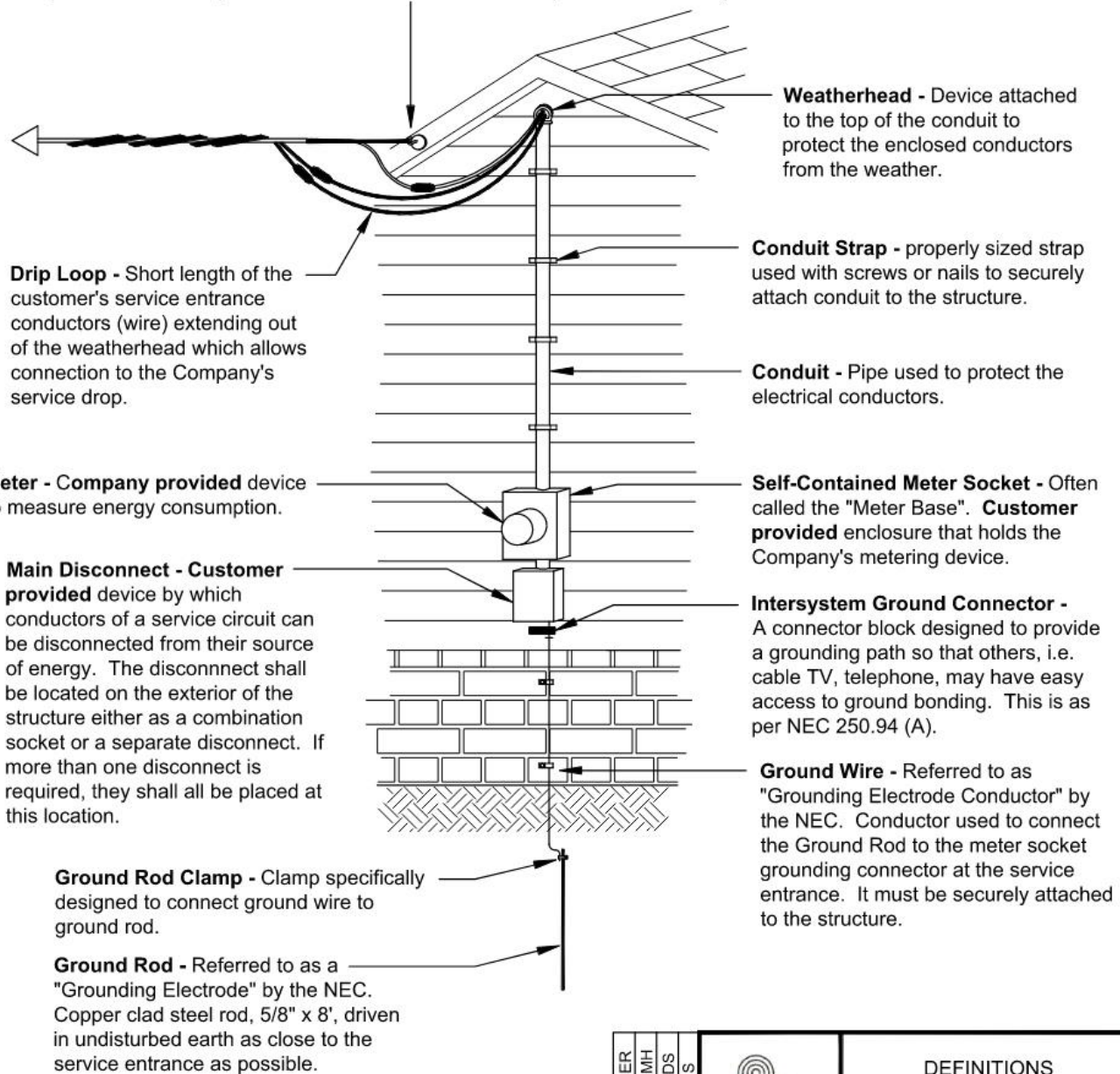

02/05/21 DER 03/13/18 KMH 12/30/04 SDS REVISIONS	 Liberty	DEFINITIONS	
		DRAWN: JEB	DWG. NO. G18A2020
		SCALE: NTS	FIGURE 1
		DATE: 5/13/96	

Figure 1: Definitions

DEFINITIONS ONLY

**REFER TO INSTALLATION SPECIFICATION AND FIGURES
FOR CONSTRUCTION DETAILS.**

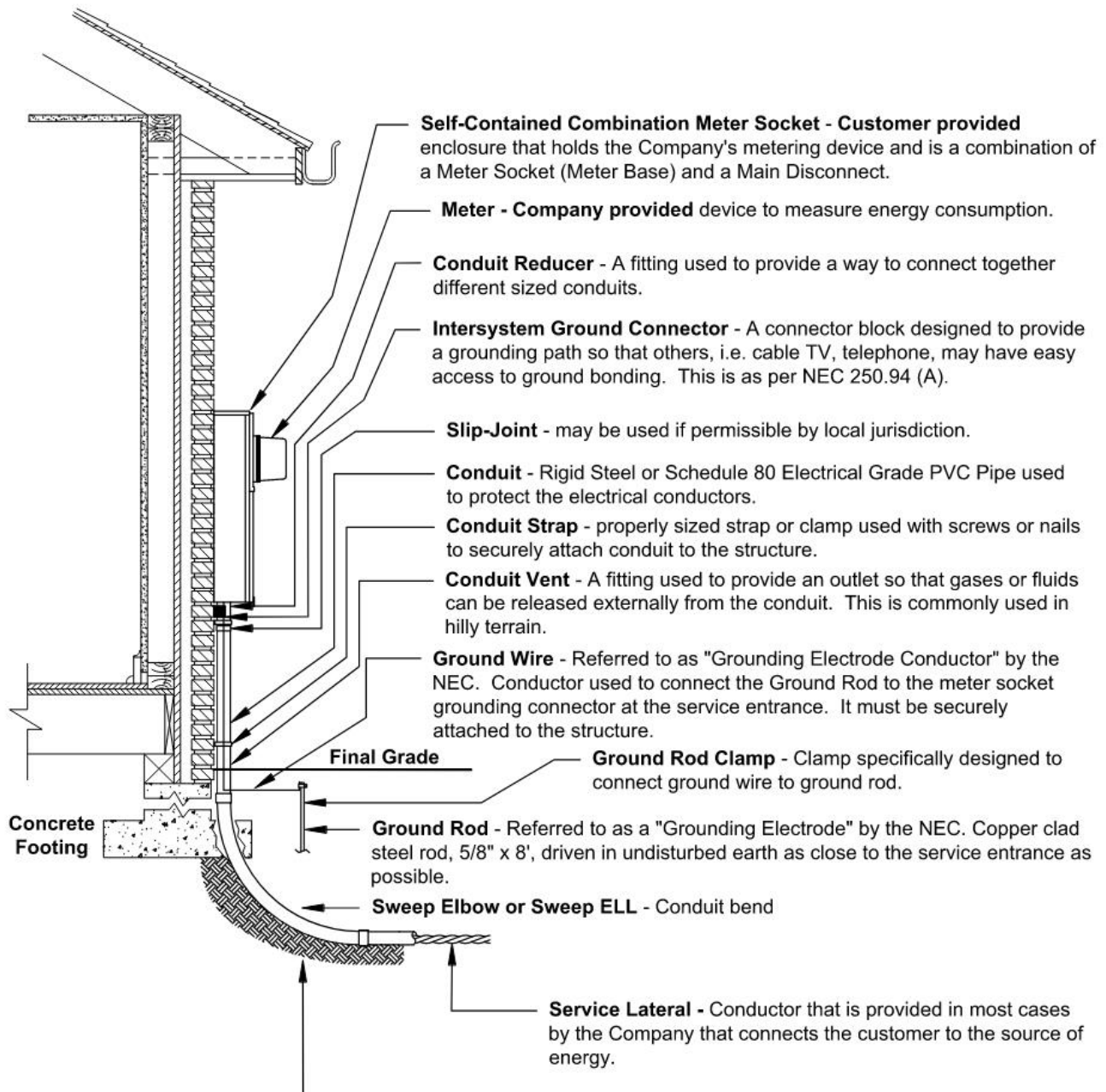

Undisturbed Earth - Soil that has not been moved by construction or recompact soil that approximates such. In engineering terms, it is top soil or clay void of rotting debris that has been recompact in 1 foot lifts to the desired level using a vibrating roller or sheeps-foot roller and achieving a 95% modified Proctor Density at each lift.

02/04/21 DER	 Liberty	DEFINITIONS	
07/17/19 KMH		DRAWN: SDS	DWG. NO. G18A2021
SDS 01/26/09		SCALE: NTS	FIGURE 2
REVISIONS		DATE: 11/06/06	

Figure 2: Definitions

DEFINITIONS ONLY

LINE OF SIGHT CAN BE DETERMINED BY AN ANGLE OF 160 DEGREES FROM THE METER SOCKET LOCATION.

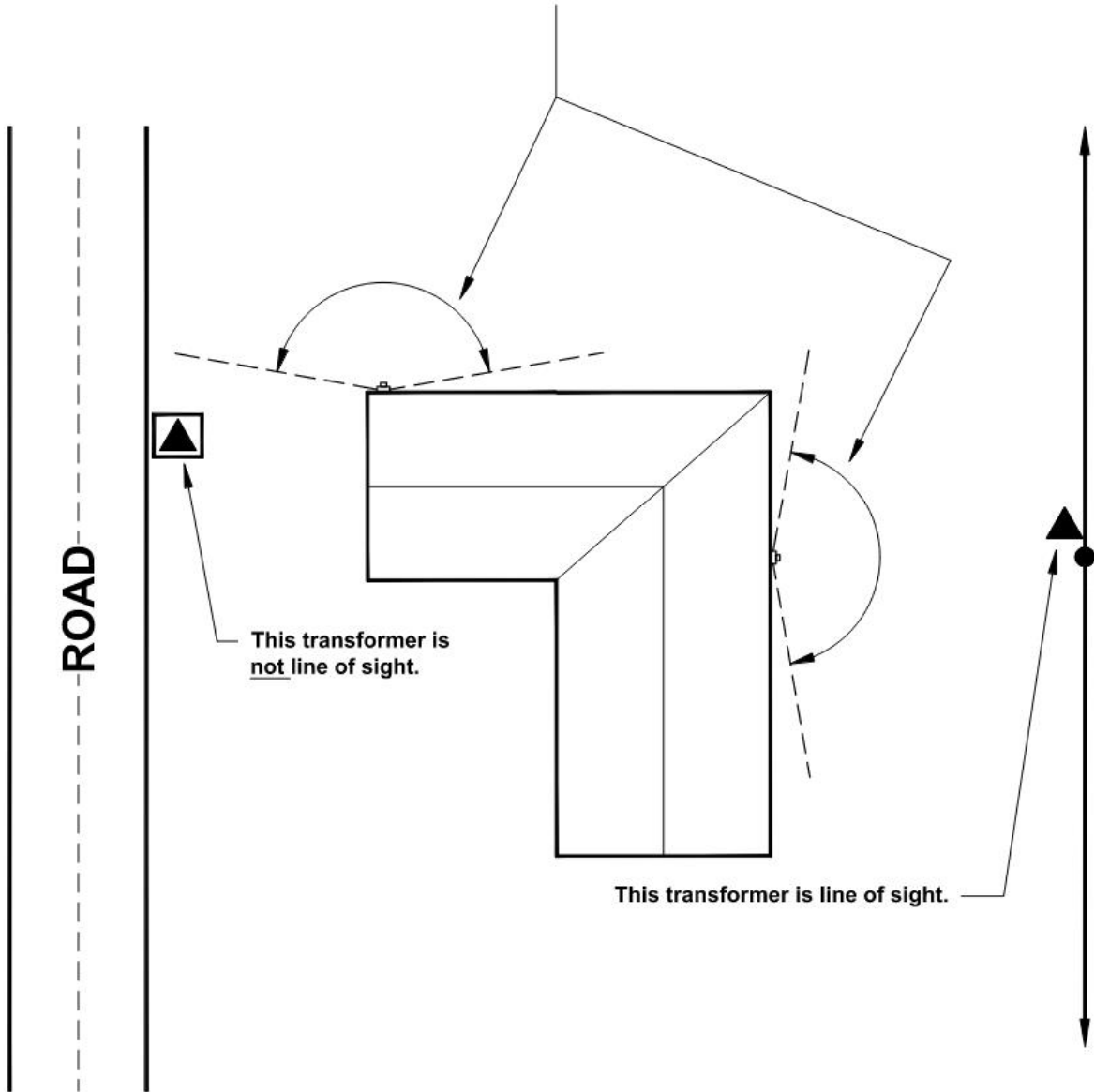

02/05/21 DER 04/19/18 KMH REVISIONS	 Liberty	DEFINITIONS	
		DRAWN: SDS	DWG. NO. G18A2022
		SCALE: NTS	FIGURE 3
		DATE:10/01/09	

Figure 3: Definitions

2.2 AVAILABILITY AND LOCATION OF SERVICE

Before construction is started, the Customer shall request the Company to designate a point of delivery, and submit appropriate load data to the Company. The load data should include the anticipated demand and list of equipment. The Customer shall provide a set of building plans, a survey and a copy of the warranty deed. It is requested that the Customer provide the building plans as an AutoCAD file (.DWG) format.

It is important that the Company and Customer be in agreement on the planned location of all service-related equipment before construction is started. This equipment includes, but may not be limited to; meter sockets, risers, pedestals, conduit and trench location, pull boxes, padmounted transformers, CT/connection cabinets, pole, lines and anchors.

The Customer is responsible for contacting customer service in order to submit a request to open a billing account before any permanent service can be installed. Customer Service can be reached by calling:

(800) 206 – 2300.

Failure to comply could result in time delays and/or additional cost to the Customer.

2.3 TYPE AND CHARACTER OF SERVICE

1. It is essential that the customer consult the company regarding type of service which can be furnished at a particular location before proceeding with purchase of equipment or installation of wiring.
2. The voltage and/or number of phases which will be supplied will depend on the type, size and location of the load, and existing Company facilities.
 - a. The table below lists the standard service voltages that are available.

	Pole Mounted Transformer	Pad Mounted Transformer
SINGLE PHASE	120/240 Volts, 3-Wire Up to 167 KVA	120/240 Volts, 3-Wire Up to 167 KVA
SOME COMMERCIAL AREAS*	120/208, 3-Wire	120/208, 3-Wire

- b. Single-phase, three-wire service will be provided according to the following:
 - (1) Customers located in predominantly residential areas will normally be provided with only single-phase 120/240 volt service.
 - *(2) Customers located in commercial/industrial areas may be provided with 120/208 volt service. Contact the Company for more details.

2.4 GENERAL REQUIREMENTS

1. The Customer's wiring and electrical equipment shall be safe, in conformance with the NEC and with all applicable federal, state, and local codes and ordinances.
2. The Main Disconnect ampacity determines the wire size used in the Service Riser as well as the wire size from the Meter Socket to the Main Disconnect.
3. **All wiring installations must be inspected and approved by an authorized electrical inspector as required by governmental authority.**

The Company shall have the right to disconnect or refuse service to any installation which violates local, municipal, NEC or NESC regulations. The Company shall also have the right to disconnect or refuse service for installations that are hazardous to the public or negatively impact service to other Customers or Company facilities.

4. Before service can be connected, the 911 address must be displayed at the location.

2.5 ALTERATIONS AND ADDITIONS

1. **SERVICE CONNECTIONS, METERS, OR METERING EQUIPMENT SHALL NOT BE REMOVED OR RELOCATED EXCEPT BY EMPLOYEES OF THE COMPANY OR ITS AUTHORIZED AGENTS.**
2. Connection to the Customer's premises is made with facilities designed to properly supply adequate electric service for the Customer's operation using information provided at the time of application for service. Therefore, no additions of major load, or alterations of the Customer's installation should be made without first notifying the Company. Failure to provide such notification may affect the quality and reliability of the Customer's own service, as well as that of other Customers.
3. When alterations or repairs require the relocation or temporary removal of service drop wires, meters and metering equipment, the Customer shall make appropriate advance arrangements with the Company to perform the relocation or temporary removal. The new location must be approved by the Company before the Customer begins work. All alterations or repairs must meet the applicable codes that are in effect at the time work is done. When alterations or repairs have been satisfactorily completed by the Customer and the necessary inspection approvals obtained, the Company will make the connections to provide service.

4. Since *serious injury or death* could result from a person coming in contact with an energized electrical circuit or equipment, neither the Customer nor the Customer's agents shall remove an energized meter from its socket. Meters are not designed to be a disconnecting device under load. Arcing, fire, explosion, etc. could occur with the possibility of burns, injury, or death as well as damage to adjacent or surrounding structures and equipment. The Customer will be held legally responsible for such injury, death, or damage if caused by the unauthorized breaking of the seals, tampering, or otherwise interfering with the Company's meter or other equipment of the Company installed on the Customer's premises. No one except authorized employees or agents of the Company will be allowed to make any repairs or adjustments to any meter or other equipment belonging to the Company. The Company will be responsible for disconnecting service and removing the meter prior to the Customer's repair or replacement of the Customer's meter socket.

3.0 METERING

3.1 GROUNDING

1. GENERAL

Unless otherwise noted, the Customer shall supply and install a 5/8" x 8' ground rod with ground rod clamp outside of the building wall. It shall be totally driven and be within two (2) feet of the structure at the meter socket location. If other grounding methods are used, all grounding systems must be bonded together as per NEC.

2. SELF – CONTAINED

When using self-contained meter sockets, the ground wire shall originate at the factory installed grounding connector in the meter socket and terminate at the ground rod clamp on the ground rod. The size of the ground wire shall be as specified in the applicable drawings.

3. CURRENT TRANSFORMER (CT)

When the metering installation requires the use of current transformers, a single ground rod may not be adequate. Consult the NEC for further information.

4. MINIMUM GROUND WIRE

For services 320 amps or less, refer to the tables in the applicable drawings. For services larger than 320 amps, consult the NEC.

3.2 METERING EQUIPMENT LOCATIONS

1. The metering equipment shall be located outdoors and approved by the Company.
2. Metering equipment shall be located where it is readily accessible to Company employees without special keys or entry requirements (public entry).
3. Metering accuracy is of utmost importance to the Company and its Customers. Therefore, any location where the environment could affect the accuracy of the meter will not be acceptable. These conditions could include, but are not limited to: corrosion, vibration, dust, magnetic interference, etc.

4.0 INFORMATION APPLYING TO ALL SERVICES

1. There will only be one service voltage available at a location, and only one point of delivery for each building, except as allowed by the NEC and approved by the Company. If multiple service points are approved by the Company, the service points shall be marked as per NEC 230.2.E. Engraved plaques shall be attached with screws, bolts, or rivets.
2. **The point of delivery shall be designated by the Company prior to beginning construction.**
3. **All utilities must be notified, and all underground facilities located and marked prior to any excavation. This shall include any Customer owned facilities.**
4. All service entrance facilities, including meter sockets, shall be located in an exposed and readily accessible area.
5. **Copper conductors are highly recommended.** Where allowed by local authority, aluminum conductors may be installed per NEC requirement; provided the meter socket is approved for use with aluminum conductors, and a corrosion inhibiting compound recommended by the cable manufacturer is properly applied to the meter socket terminals. **Conductor ampacities used in the wire tables are based on 75 degrees C as per NEC 310.16.**
6. When an existing service entrance using copper conductors is replaced by a service entrance using aluminum conductors, the existing meter socket, if not marked AL-CU, must be replaced with one approved for use with aluminum conductors.
7. Service entrance conductors between the Company's point of delivery and the self – contained metering point, or the first disconnect shall be enclosed in conduit. **Troughs and electrical gutters are not allowed on either side of disconnects on the outside of the building.**
8. Unless otherwise noted, the conduit is to be galvanized rigid steel. **Water pipes, sewer pipes and / or fittings are NOT acceptable.** Unless otherwise stated all sweep ells shall be rigid steel, and the following minimum sweep radius of these will be; 4" – 16", 3" – 13", and 2" – 9.5".
9. The neutral conductors of all services shall be grounded at the metering point as shown on the applicable drawings.
10. All neutral conductors shall be clearly marked with white tape at the point of delivery and at the meter location.
11. **Bypass levers are allowed on 320 Amp meter sockets only.**

5.0 TEMPORARY SERVICES

1. The Company must be provided with detailed plans of each installation where temporary service is to be supplied. Installations requiring special service, meter, or other work for construction purposes, exhibits of short duration, etc., **will be made at the expense of the Customer.**
2. Temporary services over 300 feet are not available. **The Company will not be responsible for damage done to equipment with temporary services.**
3. **Temporary service equipment shall not be installed on trees or the Company's Poles.**
4. Temporary installation of service entrance, other wiring, and meters shall meet the same requirements as permanent installations, including inspection and approval.
5. **Temporary single phase service for construction purposes may be provided from either overhead or underground facilities. Arrangements for temporary construction service are shown in Figures 4, 5, and 6.**
6. Prior to connection of permanent service, all temporary service drops or temporary construction wires or cables shall be removed from the finished structure's permanent distribution panels.
7. The typical temporary service is 120/240v, single phase. Single phase temporary service requiring over 100 amps capacity may be available. Contact the Company for more details, additional costs may apply.

8. All temporary installations shall be safe and in good working condition as judged by a Company field representative before the service will be connected.

9. Temporary service will be available at the site as long as construction is in progress or is otherwise limited by the Local Authority. Once the project is substantially completed the temporary service shall be disconnected.
10. Liberty is not required to provide electric service to temporary Customers at locations that require the extension of Company lines unless the full cost of erection and removal, including indirect costs of construction, of the extension by contributed by the Customer.

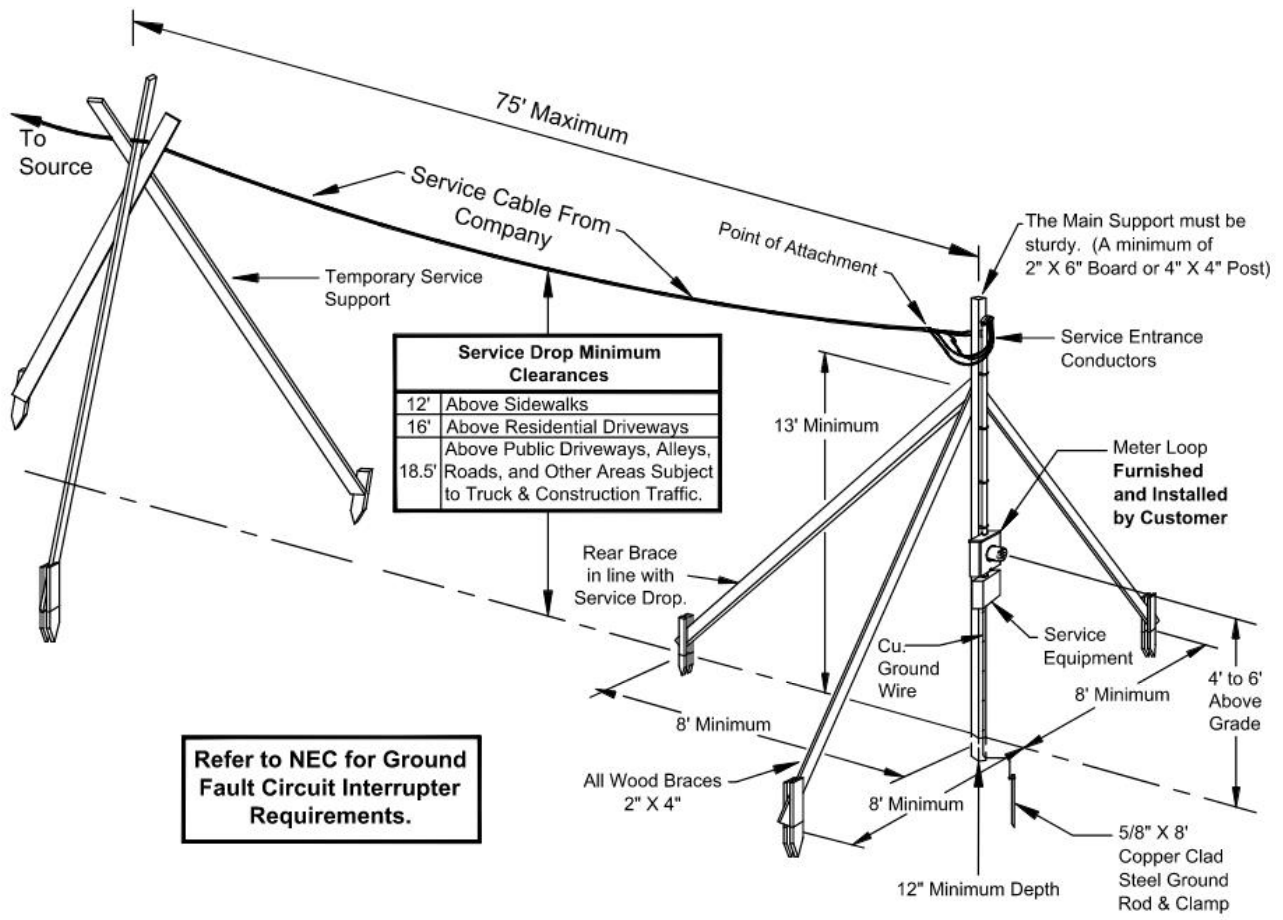

Service Drop Minimum Clearances	
12'	Above Sidewalks
16'	Above Residential Driveways
18.5'	Above Public Driveways, Alleys, Roads, and Other Areas Subject to Truck & Construction Traffic.

Refer to NEC for Ground Fault Circuit Interrupter Requirements.

CAUTION!
Contact All Utilities Before Digging or Staking.

Service Size	Wire Sizes	
	Neutral*	Line
100 Amp	#4 Cu.	#4 Cu.
	#2 AL.	#2 AL.

* Neutral May Be Reduced Under Specific Conditions Allowed By NEC.

Service Size	Ground Wire
100 Amp	#6 Cu.

All Equipment Furnished and Installed By Customer Unless Otherwise Noted.

02/04/21	DER
07/15/19	KMH
01/18/13	SDS
10/01/09	SDS
07/15/06	SDS
05/17/05	SDS
01/01/97	AMA
REVISIONS	

Temporary Service From Overhead Facilities

DRAWN: LU	DWG. NO. G18A2023
SCALE: NTS	FIGURE 4
DATE: 01/01/95	

Figure 4: Temporary Service from Overhead Facilities

Refer to NEC for Ground Fault Circuit Interrupter Requirements.

Service Size	Minimum	
	Neutral*	Line
100 Amp	#4 Cu.	#4 Cu.
	#2 AL.	#2 AL.

* Neutral May Be Reduced Under Specific Conditions Allowed By NEC.

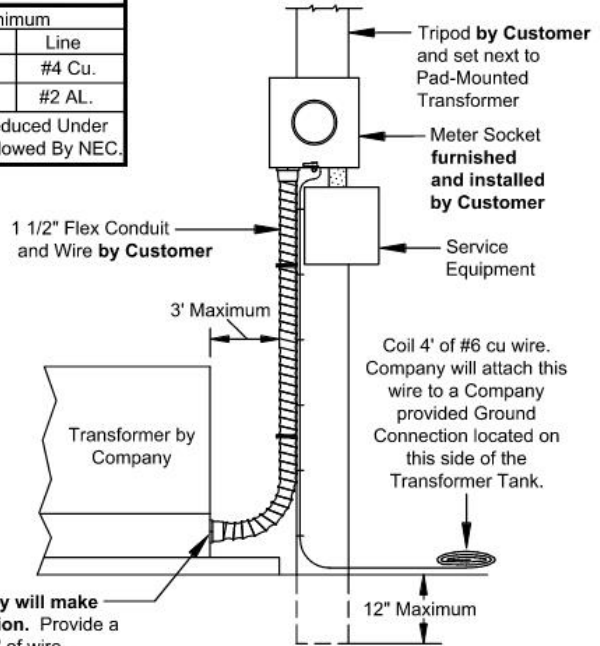
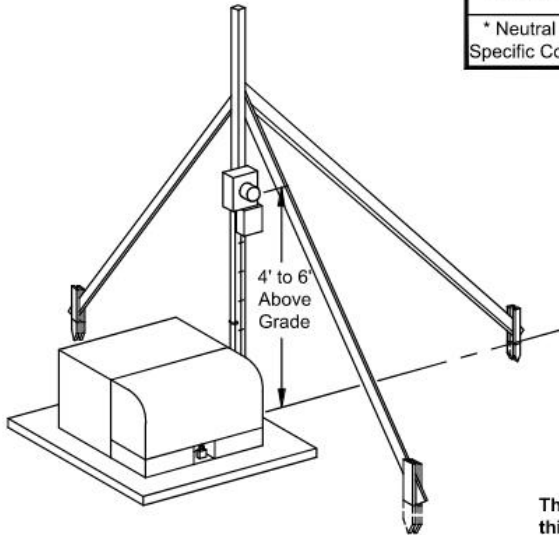

Temporary Meter Loop Shall Be As Shown.

CAUTION!
Contact All Utilities Before Digging or Staking.

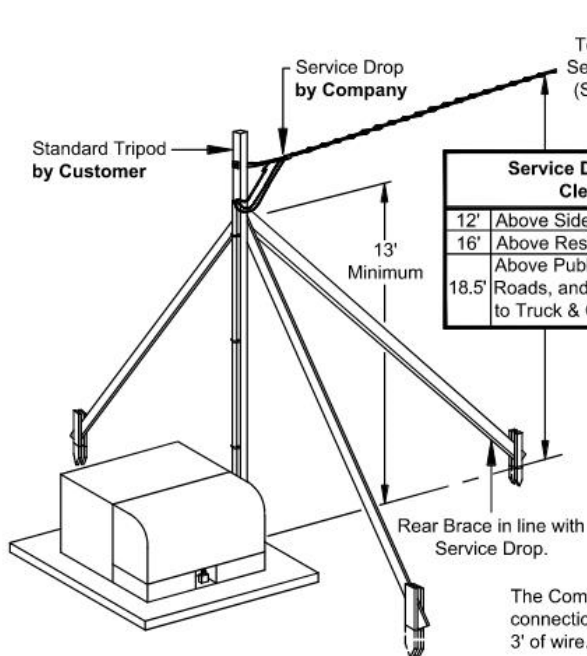

Service Drop Minimum Clearances	
12'	Above Sidewalks
16'	Above Residential Driveways
18.5'	Above Public Driveways, Alleys, Roads, and Other Areas Subject to Truck & Construction Traffic.

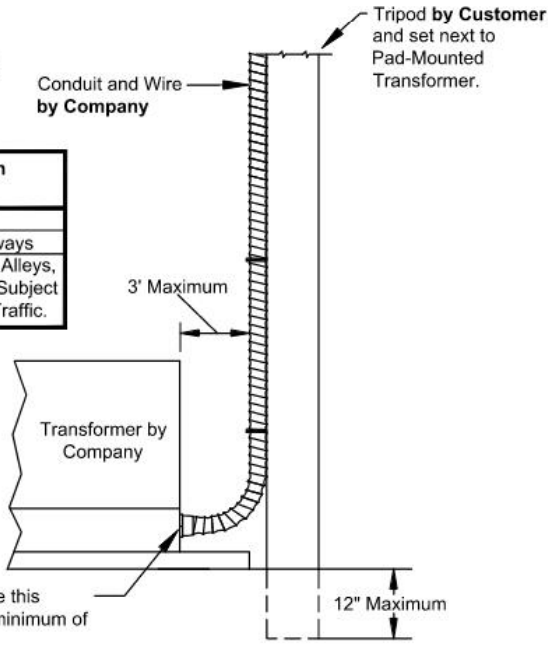

All Equipment Furnished and Installed By Customer Unless Otherwise Noted.

02/05/21	DER
07/15/19	KMH
02/18/13	SDS
07/15/06	SDS
05/17/05	SDS
REVISIONS	



Temporary Service From Underground Facilities	
DRAWN: LU	DWG. NO. G18A2024
SCALE: NTS	FIGURE 5
DATE: 01/01/97	

Figure 5: Temporary Service from Underground Facilities

Refer to NEC for Ground Fault Circuit Interrupter Requirements.

Service Size	Minimum	
	Neutral*	Line
100 Amp	#4 Cu.	#4 Cu.
	#2 AL.	#2 AL.

* Neutral May Be Reduced Under Specific Conditions Allowed By NEC.

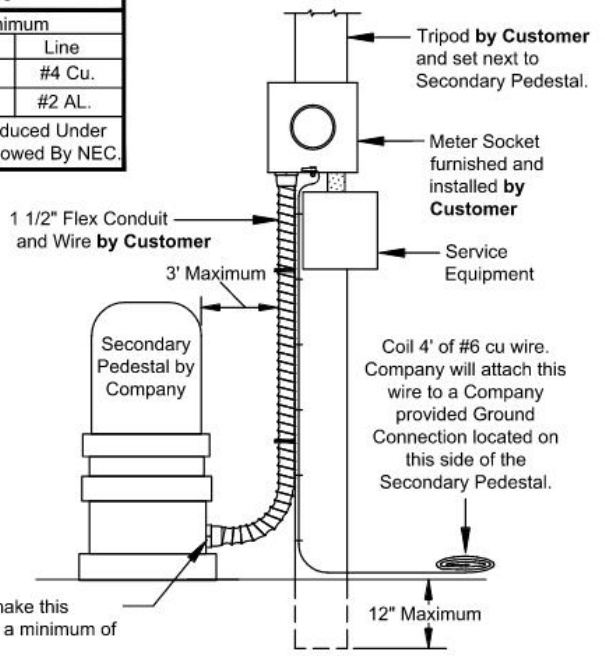
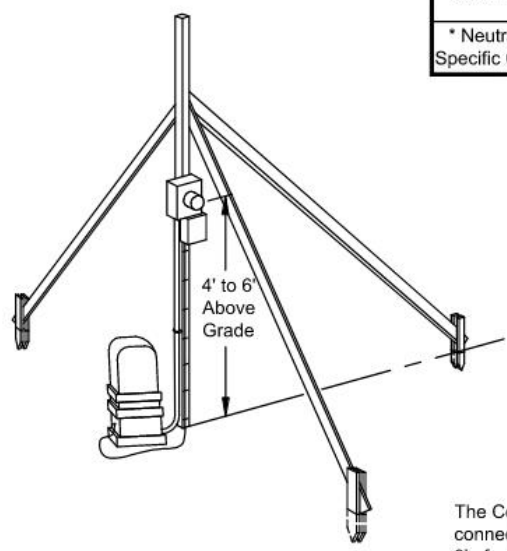

The Company will make this connection. Provide a minimum of 3' of wire.

Temporary Meter Loop Shall Be As Shown.

CAUTION!
Contact All Utilities Before Digging or Staking.

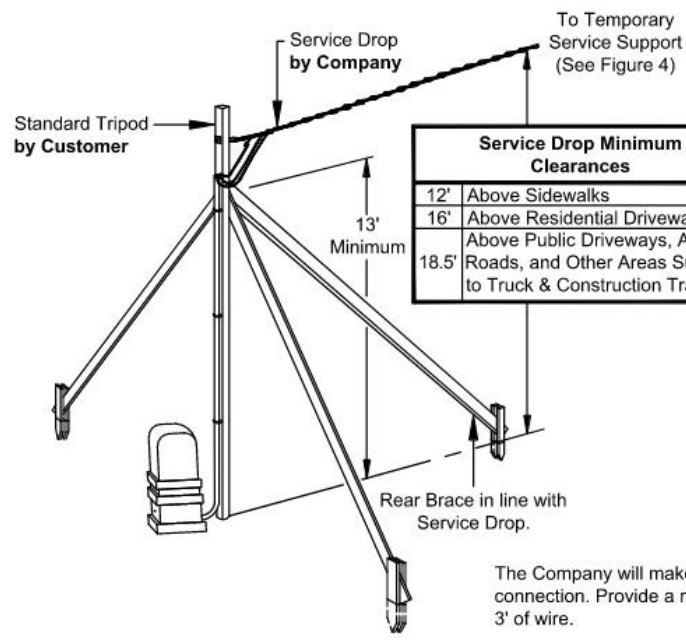

Service Drop Minimum Clearances	
12'	Above Sidewalks
16'	Above Residential Driveways
18.5'	Above Public Driveways, Alleys, Roads, and Other Areas Subject to Truck & Construction Traffic.

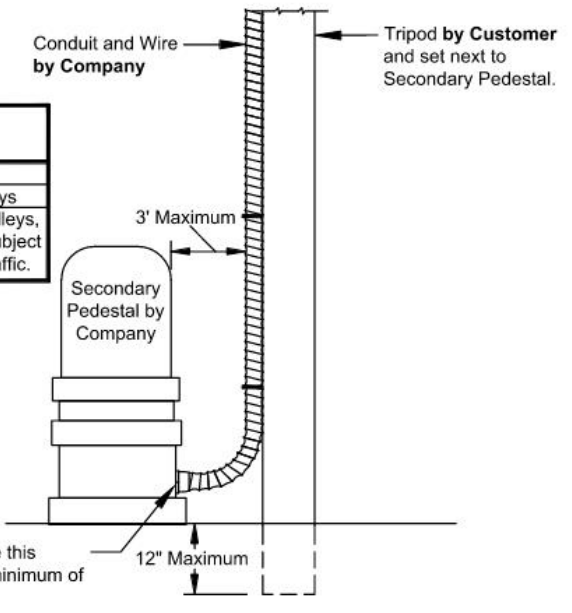

The Company will make this connection. Provide a minimum of 3' of wire.

All Equipment Furnished and Installed By Customer Unless Otherwise Noted.

02/05/21	DER
07/15/19	KMH
02/18/13	SDS
07/15/06	SDS
REVISIONS	



Temporary Service From Underground Facilities (Continued)	
DRAWN: LU	DWG. NO. G18A2025
SCALE: NTS	FIGURE 6
DATE: 01/01/97	

Figure 6: Temporary Service from Underground Facilities (Continued)

RESERVED FOR FUTURE USE

Figure 7: (Future Use)

6.0 OVERHEAD SERVICES

6.1 GENERAL INFORMATION

1. The Customer shall provide an insulated Point of Attachment within 24" of the weatherhead which is capable of withstanding a continuous force of 200 lbs. in the direction of pull of the Service Drop. The weatherhead shall be above the point of attachment, where practical. The weatherhead location shall not be farther than 24 inches from the Point of Attachment.
2. A minimum of 24 inches of service entrance conductor shall extend from a single weatherhead for connection to the service drop.
3. The Customer shall provide a clear and unobstructed path for the Company's service drop to the attachment point. The Customer shall request the Company to designate the location of the point of delivery for each service location before construction is started. This shall be done to increase the reliability of electric service. Trees growing into or near power lines are one of the most common causes of power outages. Help avoid the need for future trimming by planting the right tree in the right place. For a list of appropriate trees for the TALL ZONE, MEDIUM ZONE AND LOW ZONE pictured below, please contact your Liberty representative.

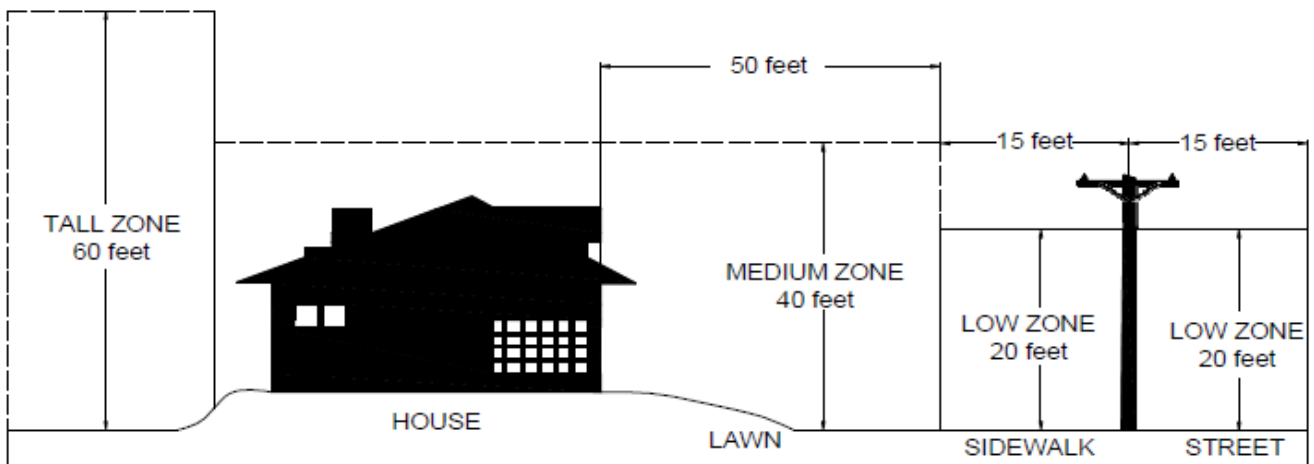

4. The point of attachment of the service drop conductors shall be located by the Customer so as to allow not less than the minimum clearances for the service drop as shown in the table below. Greater clearances may be required by local authorities. **In no case shall the attachment height be lower than 12' above final grade.**

MINIMUM CLEARANCES OF SERVICE DROP CABLES*

Above roads, streets, alleys, parking lots, commercial and industrial driveways subject to truck traffic	18.5 feet
Above residential driveways	16 feet
Above space accessible to pedestrians only (including decks and porches).....	12 feet
Above or below roofs or balconies accessible to pedestrians	11 feet
Above or below roofs or projections not accessible to pedestrians	8 feet
Horizontal to any structure.....	5 feet
Horizontal from directly below conductor to edge of swimming pool	10 feet

(This is for either an above ground or in ground swimming pool.)

**Note: The point of attachment shall normally be 2' - 3' higher than these minimum required clearances to allow for sag of the service cable.*

5. Street access driveways, where vehicular traffic may pass under service conductors, must maintain the minimum clearances from ground to service conductors required for roads, streets, alleys, and parking lots in the above table. For further details and items not covered above, contact the Company.
- 6. The point of delivery will be at the weatherhead connections.**

6.2 100 AMP, 200 AMP, AND 320 AMP SINGLE PHASE OVERHEAD SERVICES

A. General Notes:

1. Service entrance conductors, 5/8" x 8' copper clad steel ground rod, ground rod clamp, ground wire, conduit, conduit straps, weatherhead, lock nuts, bushings, meter socket, meter socket hub, service drop attachment device, and miscellaneous mounting hardware furnished and installed by the Customer.
2. Meter, service connectors, and service drop furnished and installed by Company.
3. The meter socket should be "readily accessible" (see definitions). The Company requires a level and unobstructed workspace of 78 inches tall, 18 inches on either side, and 48 inches in front of the meter socket. Prior approval is required for placement of the meter socket in alleyways or areas where it may be subjected to damage.
4. The 100 Amp, 200 Amp and 320 Amp meter sockets shall meet the following specifications:
 - a. The latest revision of U.L. 414 and ANSI C12.7 Standards.
 - b. Must be U.L. listed.
 - c. Must have grounding connector for triplex.
 - d. Lug size – 2/0 minimum.
 - e. On 120/208v services, the customer must provide the meter socket with 5th lug installed in the 9 o'clock position.
 - f. See Appendix A for list of approved meter sockets.**
5. Installation requiring a steel service mast shall be installed by the Customer as specified in Figure 9.

B. Mounting:

1. Meter socket, ground wire, and conduit shall be surface mounted and securely fastened to the structure. The meter socket shall be installed in a level and plumb position. **Flush mounted or recessed metering equipment and service riser conduit embedded in a wall will not be permitted.**
2. Where the exterior wall is other than brick or concrete blocks, a supporting frame shall be installed behind the exterior wall to provide a solid mounting surface for the meter socket.
3. Meter sockets, metering cabinets, and conduit straps shall be installed with the following:
 - a. Lead anchors or double helix concrete screws shall be used with brick or solid concrete surfaces.
 - b. Toggle bolts shall be used with other masonry siding.
 - c. Wood screws shall be used with solid wood surfaces.
 - d. All mounting hardware shall be minimum #12(1/4") corrosion resistant screws.
 - e. A minimum of 4 fasteners shall be used to install any socket or cabinet unless specifically stated otherwise.
4. An intersystem bonding termination bar shall be installed to facilitate the connection of other utility's ground to a common ground. The location of this device shall be located directly below the meter socket or meter combination socket.
 - a. See Appendix A for list of approved intersystem bonding termination bars.**
5. Wire not enclosed in conduit shall be a minimum of 36 inches away from any window or door opening.

C. Connections:

1. Do not score line or load wire when removing insulation.
2. The Customer shall use wire brush or sandpaper to clean all conductors, apply a non-grit type inhibitor and tighten to manufacturer's specifications.

D. Conductor Marking:

All neutral conductors shall be clearly marked with white tape at the point of delivery and at the meter socket.

Minimum Attachment Height shall be 12' above final grade. The Customer shall provide an insulated Point of Attachment within 24" of the Weatherhead which is capable of withstanding a continuous force of 200 lbs. in the direction of pull of the Service Drop.

A minimum of 24" of wire shall be provided by the Customer. The Neutral shall be marked with white tape. The wire shall be marked or listed as Sunlight Resistant as per NEC 310.10 (D).

The path to the Service Pole shall be clear of trees and building debris and materials.

Service Drop Minimum Clearances	
12'	Above Sidewalks
16'	Above Residential Driveways
18.5'	Above Public Driveways, Alleys, Roads, and Other Areas Subject to Truck & Construction Traffic.

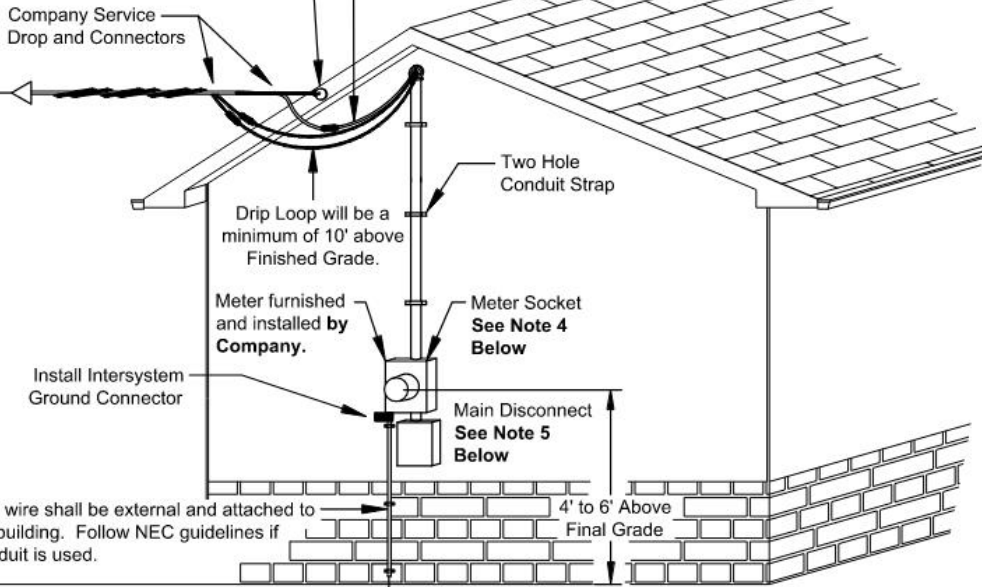

Service Size	Ground Wire
100 Amp	#6 Cu.
200 Amp	#4 Cu.
320 Amp	1/0 Cu.

All Grounding Systems shall be bonded together.

Service Size	Wire Sizes		Conduit Size	Wire Sizes		Conduit Size	Conduit Type ***
	Minimum			Recommended			
	Neutral**	Line		Neutral**	Line		
100 Amp*	#4 Cu.	#4 Cu.	1 1/4"	#3 Cu.	#3 Cu.	1 1/4"	Galv. Rigid Steel
	#2 AL.	#2 AL.	1 1/4"	#1 AL.	#1 AL.	1 1/2"	Galv. Rigid Steel
200 Amp	2/0 Cu.	2/0 Cu.	2"	3/0 Cu.	3/0 Cu.	2"	Galv. Rigid Steel
	4/0 AL.	4/0 AL.	2"	250 AL.	250 AL.	2 1/2"	Galv. Rigid Steel
320 Amp	2 - 4/0 Cu.	2 - 4/0 Cu.	3"	2 - 4/0 Cu.	2 - 4/0 Cu.	3"	Galv. Rigid Steel
	2 - 300 AL.	2 - 300 AL.	4"	2 - 300 AL.	2 - 300 AL.	4"	Galv. Rigid Steel

* 100 Amp allowed on overhead service only.
 ** Neutral May Be Reduced Under Specific Conditions Allowed By NEC.
 *** Other types of conduit allowed depending on local code.

Ground Rod and Wire **MUST** be Installed and Ground Wire **MUST** be attached to the structure before Service will be Connected.

Notes:

1. If minimum vertical clearance cannot be maintained with the installation of an attachment as shown above, the **Customer** shall install a rigid steel service mast as shown in Figure 9.
2. Connections between the Service Drop and Service Entrance Conductors shall be made by **Company Personnel** below the Weatherhead, forming a Drip Loop.
3. Other types of conduit may be allowed depending on Local Code Requirements. These may include EMT, Electrical Grade PVC, and Rigid Aluminum. **However, the Service Drop shall not be attached to any of these.**
4. 100 amp, 200 amp and 320 amp meter sockets shall be furnished by the customer. Bypass lever allowed on 320 amp meter socket only.
5. The disconnect shall be located on the exterior of the structure either as a combination socket or an separate disconnect. If more than one disconnect is required, they shall all be placed at this location. It shall not be closer than 1" nor farther than 1' from the meter socket.

All Equipment Furnished and Installed By Customer Unless Otherwise Noted.

02/05/21	DER
08/14/19	KMH
12/08/08	SDS
07/15/06	SDS
05/17/05	SDS
01/01/97	AMA
REVISIONS	



100/200/320 Amp Overhead Service	
DRAWN: LU	DWG. NO. G182027
SCALE: NTS	FIGURE 8
DATE: 01/01/95	

Figure 8: 100/200/320 Amp Overhead Service

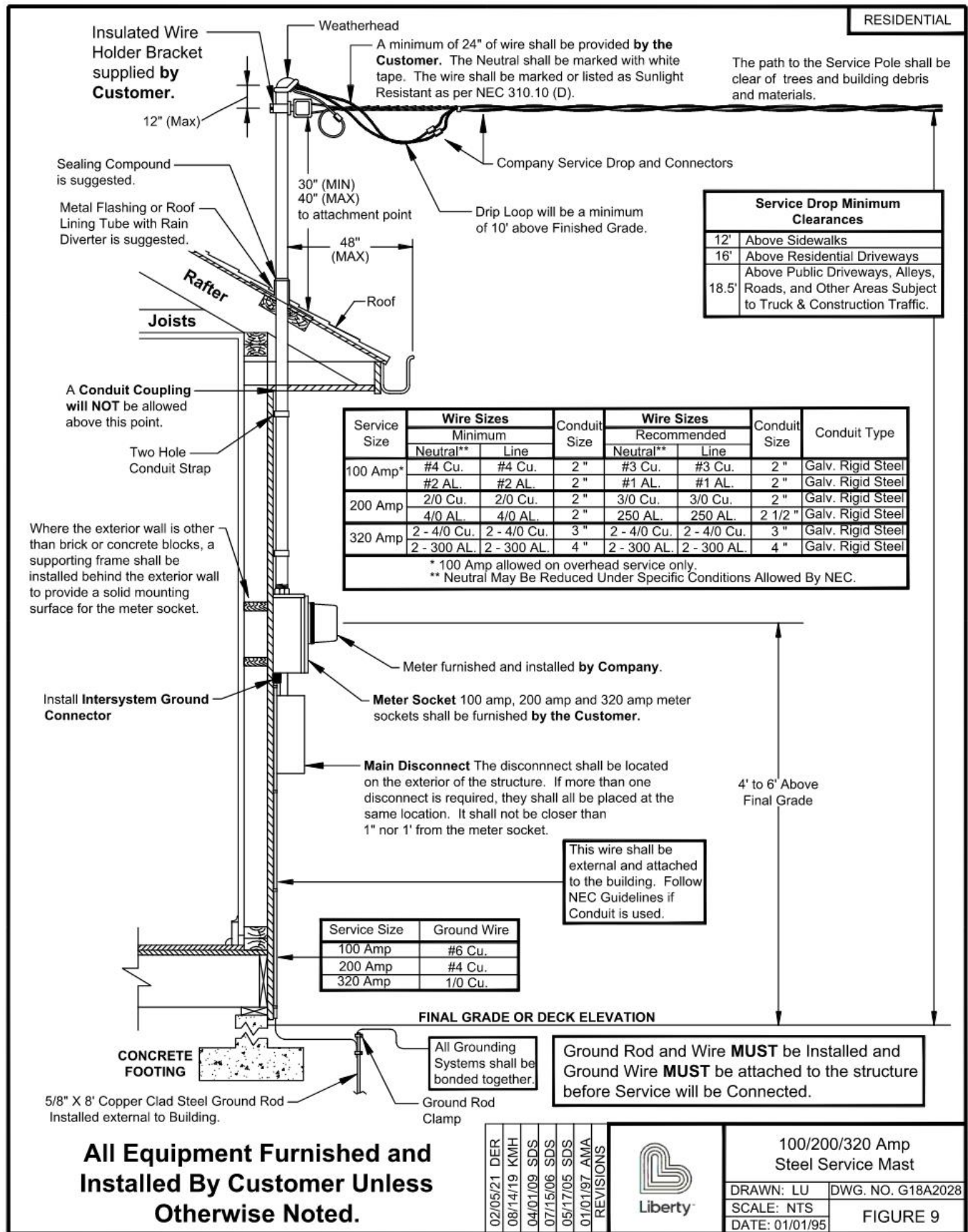

RESIDENTIAL

The path to the Service Pole shall be clear of trees and building debris and materials.

A minimum of 24" of wire shall be provided by the Customer. The Neutral shall be marked with white tape. The wire shall be marked or listed as Sunlight Resistant as per NEC 310.10 (D).

Service Drop Minimum Clearances	
12'	Above Sidewalks
16'	Above Residential Driveways
18.5'	Above Public Driveways, Alleys, Roads, and Other Areas Subject to Truck & Construction Traffic.

Service Size	Wire Sizes Minimum		Conduit Size	Wire Sizes Recommended		Conduit Size	Conduit Type
	Neutral**	Line		Neutral**	Line		
100 Amp*	#4 Cu.	#4 Cu.	2"	#3 Cu.	#3 Cu.	2"	Galv. Rigid Steel
	#2 AL.	#2 AL.	2"	#1 AL.	#1 AL.	2"	Galv. Rigid Steel
200 Amp	2/0 Cu.	2/0 Cu.	2"	3/0 Cu.	3/0 Cu.	2"	Galv. Rigid Steel
	4/0 AL.	4/0 AL.	2"	250 AL.	250 AL.	2 1/2"	Galv. Rigid Steel
320 Amp	2 - 4/0 Cu.	2 - 4/0 Cu.	3"	2 - 4/0 Cu.	2 - 4/0 Cu.	3"	Galv. Rigid Steel
	2 - 300 AL.	2 - 300 AL.	4"	2 - 300 AL.	2 - 300 AL.	4"	Galv. Rigid Steel

* 100 Amp allowed on overhead service only.
 ** Neutral May Be Reduced Under Specific Conditions Allowed By NEC.

Service Size	Ground Wire
100 Amp	#6 Cu.
200 Amp	#4 Cu.
320 Amp	1/0 Cu.

This wire shall be external and attached to the building. Follow NEC Guidelines if Conduit is used.

Ground Rod and Wire **MUST** be installed and Ground Wire **MUST** be attached to the structure before Service will be Connected.

All Equipment Furnished and Installed By Customer Unless Otherwise Noted.

02/05/21	DER
08/14/19	KMH
04/01/09	SDS
07/15/06	SDS
05/17/05	SDS
01/01/97	AMA
REVISIONS	



100/200/320 Amp Steel Service Mast	
DRAWN: LU	DWG. NO. G18A2028
SCALE: NTS	FIGURE 9
DATE: 01/01/95	

Figure 9: 100/200/320 Amp Steel Service Mast

Service Size	Wire Sizes			
	Minimum		Recommended	
	Neutral**	Line	Neutral**	Line
100 Amp*	#4 Cu.	#4 Cu.	#3 Cu.	#3 Cu.
	#2 AL.	#2 AL.	#1 AL.	#1 AL.
200 Amp	2/0 Cu.	2/0 Cu.	3/0 Cu.	3/0 Cu.
	4/0 AL.	4/0 AL.	250 AL.	250 AL.

* 100 Amp allowed on overhead service only.
 ** Neutral May Be Reduced Under Specific Conditions Allowed By NEC.

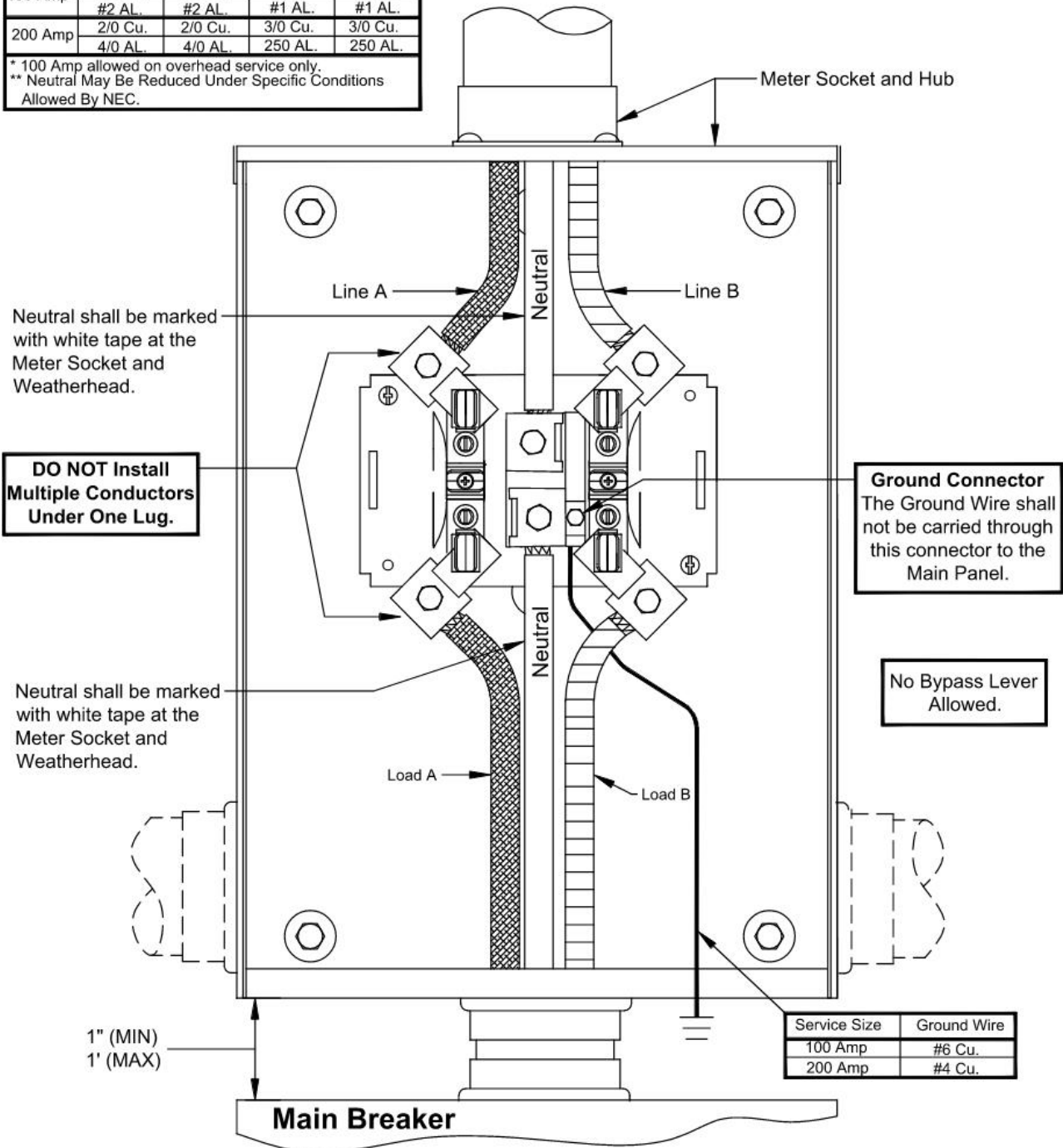

All Equipment Furnished and Installed By Customer Unless Otherwise Noted.

02/05/21 DER	06/15/19 KMH	12/26/08 SDS	05/17/05 SDS	01/01/97 AMA	REVISIONS
--------------	--------------	--------------	--------------	--------------	-----------



100/200 Amp Meter Socket, Overhead Service	
DRAWN: LU	DWG. NO. G18A2029
SCALE: NTS	FIGURE 10
DATE: 01/01/95	

Figure 10: 100/200 Amp Meter Socket, Overhead Service

Note:
This application for
120/208v, 3 wire service.

Service Size	Wire Sizes			
	Minimum		Recommended	
	Neutral**	Line	Neutral**	Line
100 Amp*	#4 Cu.	#4 Cu.	#3 Cu.	#3 Cu.
	#2 AL.	#2 AL.	#1 AL.	#1 AL.
200 Amp	2/0 Cu.	2/0 Cu.	3/0 Cu.	3/0 Cu.
	4/0 AL.	4/0 AL.	250 AL.	250 AL.

* 100 Amp allowed on overhead service only.
 ** Neutral May Be Reduced Under Specific Conditions Allowed By NEC.

Neutral shall be marked with white tape at Meter Socket and Weatherhead.

This wire must have white insulation and will be connected as shown. This wire will be provided and installed by the Customer on **Approved Meter Sockets**.

The Customer will provide and install the 5th lug on **Approved Meter Sockets**. For a list of these, refer to **Appendix A**.

DO NOT Install Multiple Conductors Under One Lug.

Neutral shall be marked with white tape at Meter Socket and Weatherhead.

1" (MIN)
 1' (MAX)

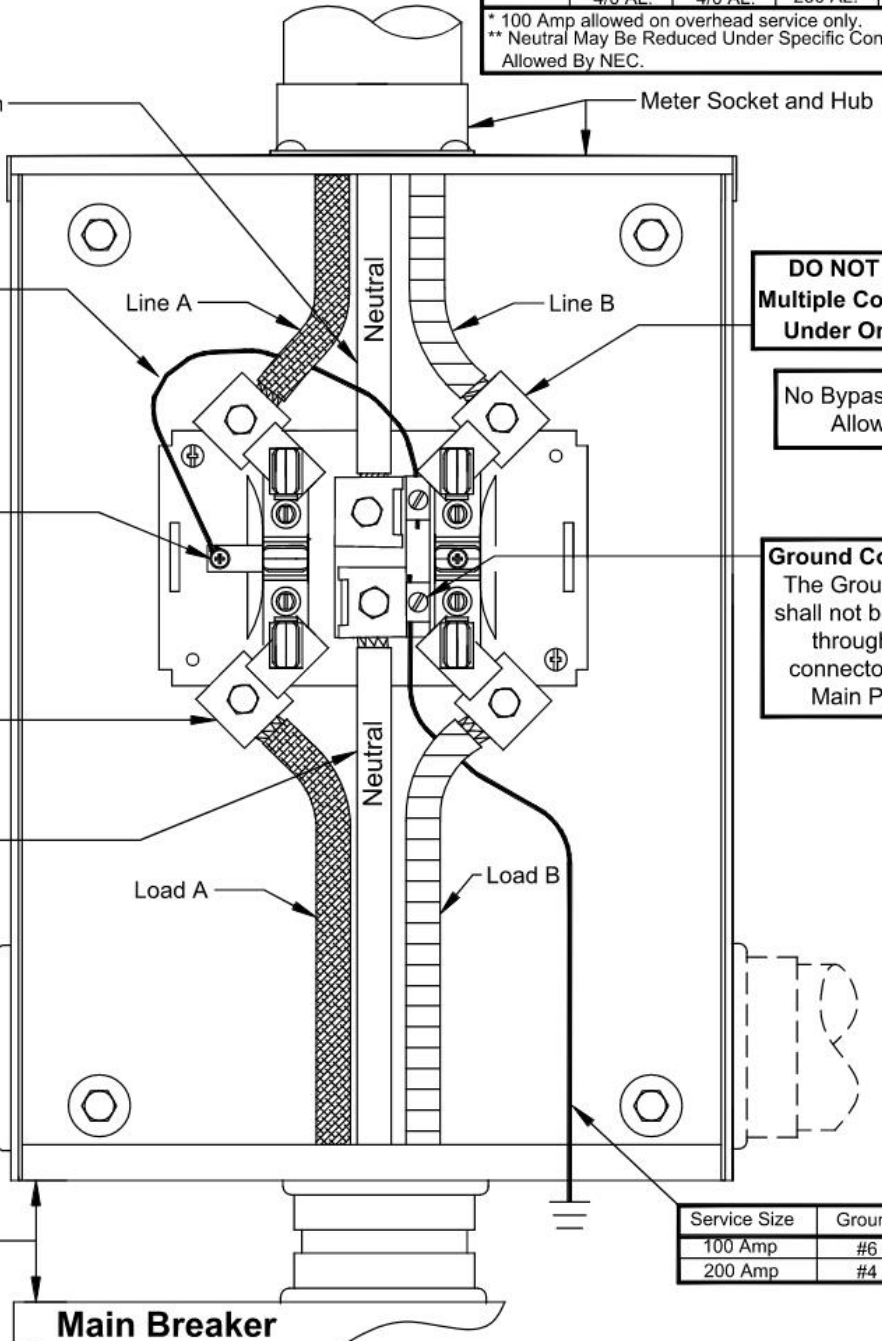

DO NOT Install Multiple Conductors Under One Lug.

No Bypass Lever Allowed.

Ground Connector
 The Ground Wire shall not be carried through this connector to the Main Panel.

Service Size	Ground Wire
100 Amp	#6 Cu.
200 Amp	#4 Cu.

All Equipment Furnished and Installed By Customer Unless Otherwise Noted.

02/05/21 DER	07/15/19 KMH	12-26-08 SDS	07-15-06 SDS	05-17-05 SDS	REVISIONS
--------------	--------------	--------------	--------------	--------------	-----------



100/200 Amp Meter Socket, Network (120/208), Overhead Service	
DRAWN: LU	DWG. NO. G18A2030
SCALE: NTS	FIGURE 11
DATE: 07/01/97	

Figure 11: 100/200 Amp Meter Socket, Network (120/208), Overhead Service

Service Size	Wire Sizes			
	Minimum		Recommended	
	Neutral**	Line	Neutral**	Line
100 Amp*	#4 Cu.	#4 Cu.	#3 Cu.	#3 Cu.
	#2 AL.	#2 AL.	#1 AL.	#1 AL.
200 Amp	2/0 Cu.	2/0 Cu.	3/0 Cu.	3/0 Cu.
	4/0 AL.	4/0 AL.	250 AL.	250 AL.

* 100 Amp allowed on overhead service only.
 ** Neutral May Be Reduced Under Specific Conditions Allowed By NEC.

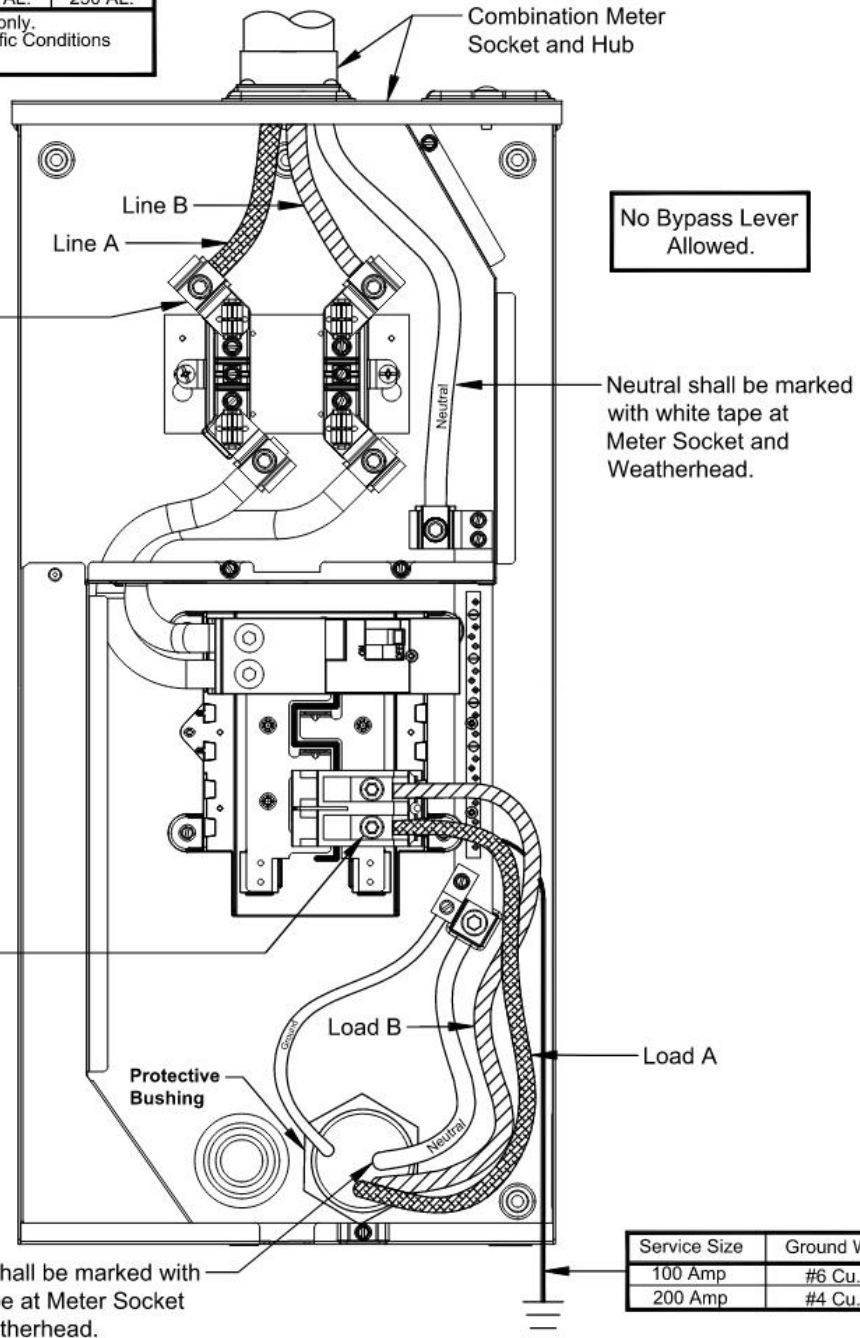

DO NOT Install Multiple Conductors Under One Lug.

DO NOT Install Multiple Conductors Under One Lug.

No Bypass Lever Allowed.

Neutral shall be marked with white tape at Meter Socket and Weatherhead.

Neutral shall be marked with white tape at Meter Socket and Weatherhead.

Service Size	Ground Wire
100 Amp	#6 Cu.
200 Amp	#4 Cu.

All Equipment Furnished and Installed By Customer Unless Otherwise Noted.

02/04/21 DER
 08/02/19 KMH
 05/16/08 SDS
 REVISIONS



100/200 Amp Combination Meter Socket

DRAWN: LU	DWG. NO. G18A2031
SCALE: NTS	FIGURE 12
DATE: 11/10/06	

Figure 12: 100/200 Amp Combination Meter Socket

Service Size	Wire Sizes			
	Minimum		Recommended	
	Neutral**	Line	Neutral**	Line
100 Amp*	#4 Cu.	#4 Cu.	#3 Cu.	#3 Cu.
	#2 AL.	#2 AL.	#1 AL.	#1 AL.
200 Amp	2/0 Cu.	2/0 Cu.	3/0 Cu.	3/0 Cu.
	4/0 AL.	4/0 AL.	250 AL.	250 AL.

* 100 Amp allowed on overhead service only.
 ** Neutral May Be Reduced Under Specific Conditions Allowed By NEC.

Note:
 This application for
 120/208v, 3 wire service.

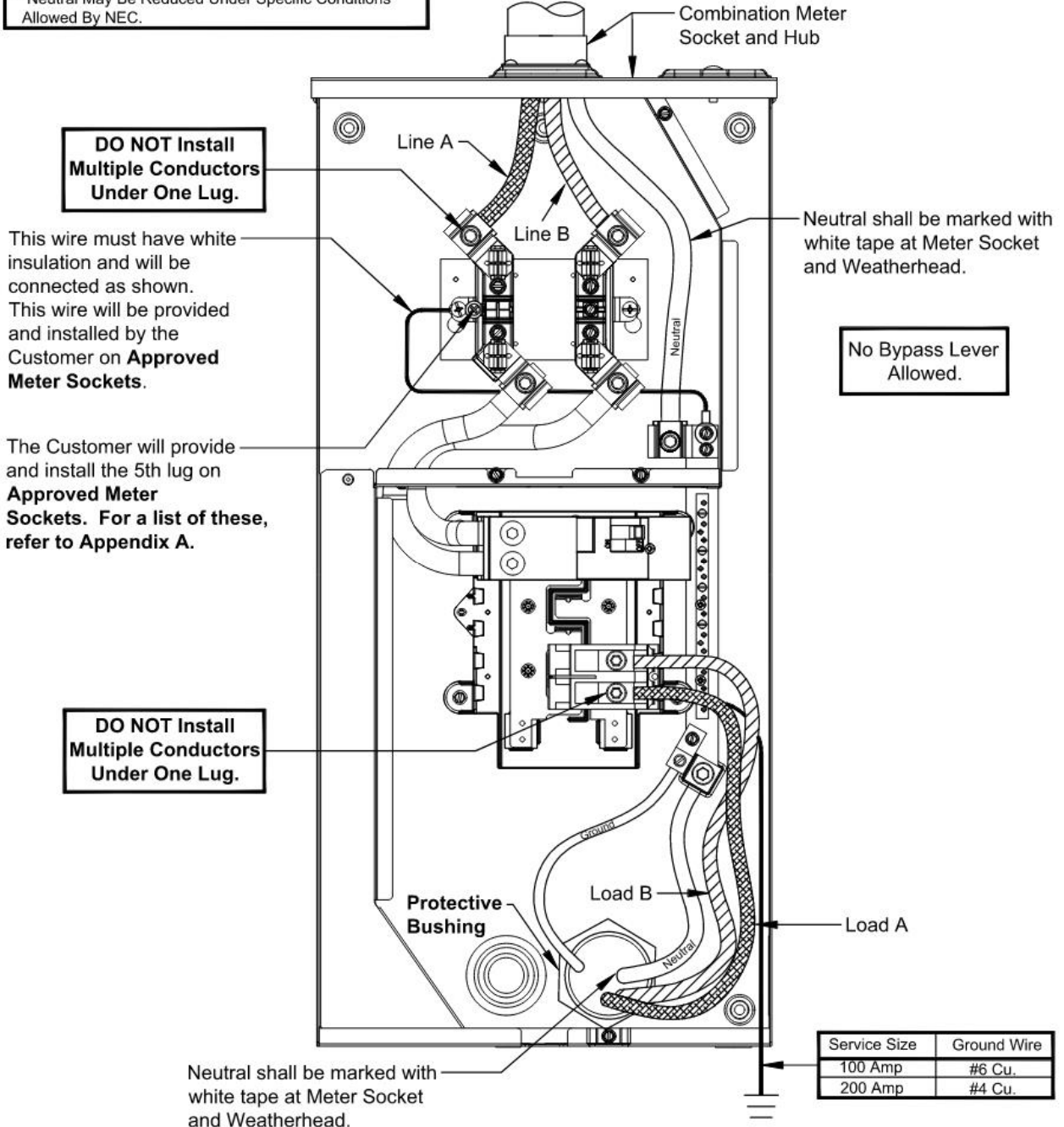

DO NOT Install Multiple Conductors Under One Lug.

This wire must have white insulation and will be connected as shown. This wire will be provided and installed by the Customer on **Approved Meter Sockets.**

The Customer will provide and install the 5th lug on **Approved Meter Sockets.** For a list of these, refer to Appendix A.

DO NOT Install Multiple Conductors Under One Lug.

Neutral shall be marked with white tape at Meter Socket and Weatherhead.

No Bypass Lever Allowed.

Service Size	Ground Wire
100 Amp	#6 Cu.
200 Amp	#4 Cu.

All Equipment Furnished and Installed By Customer Unless Otherwise Noted.

02/04/21	DER
06/11/20	SMS
08/02/19	KMH
07-10-09	SDS
REVISIONS	



100/200 Amp Combination Meter Socket, Network (120/208), Overhead Service	
DRAWN: LU	DWG. NO. G18A2032
SCALE: NTS	FIGURE 13
DATE: 11/10/06	

Figure 13: 100/200 Amp Combination Meter Socket, Network (120/208), Overhead Service

Service Size	Wire Sizes			
	Minimum		Recommended	
	Neutral*	Line	Neutral*	Line
320 Amp	2 - 4/0 Cu.	2 - 4/0 Cu.	2 - 4/0 Cu.	2 - 4/0 Cu.
	2 - 300 AL	2 - 300 AL	2 - 300 AL	2 - 300 AL

* Neutral may be reduced under specific conditions allowed by NEC.

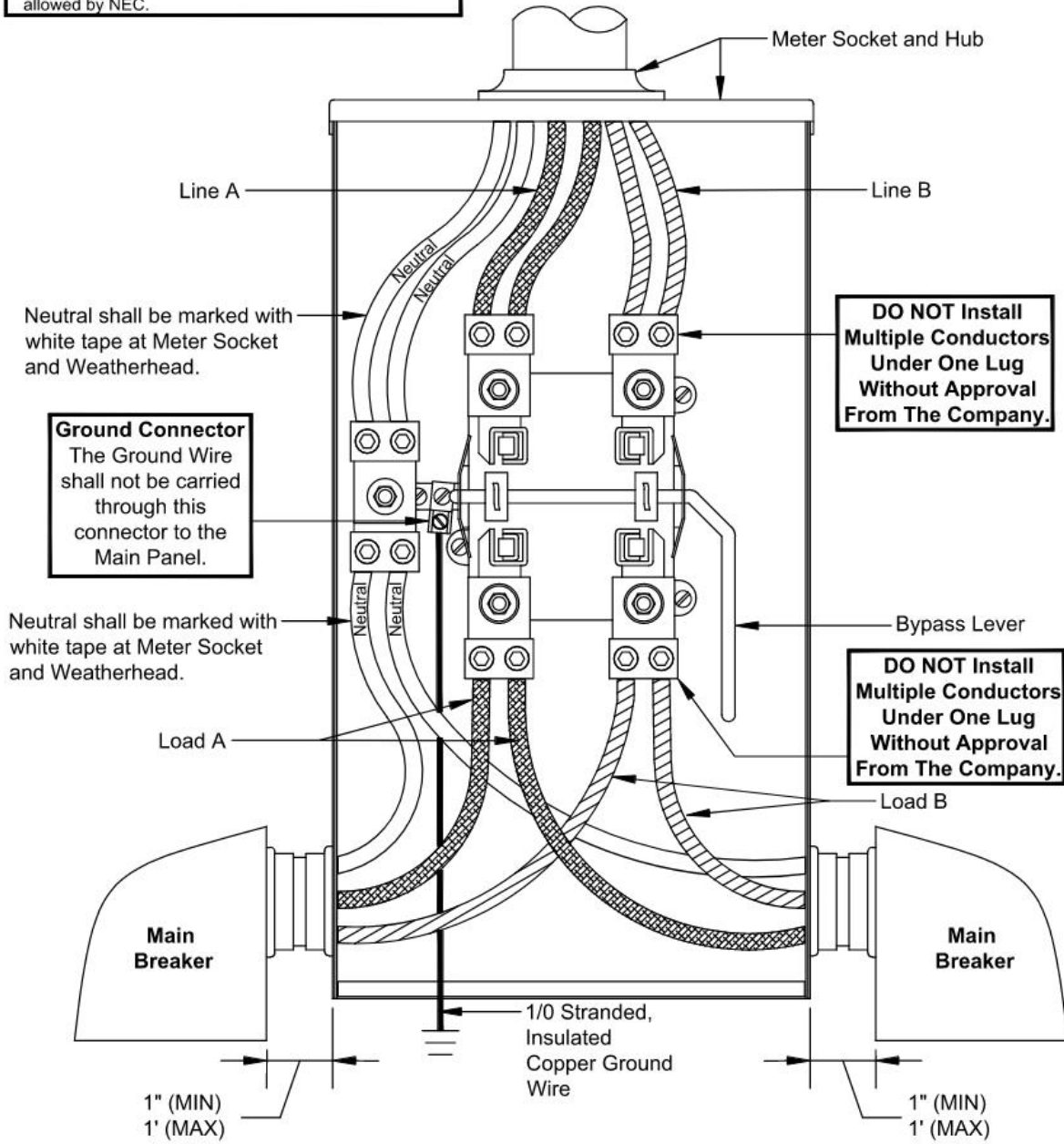

All Equipment Furnished and Installed By Customer Unless Otherwise Noted.

02/04/21	DER
01/27/21	LRs
07/01/19	KMH
03-18-10	SDS
04-01-09	SDS
05-17-05	SDS
01-01-97	AWA
	REVISIONS



320 Amp Meter Socket, Overhead Service

DRAWN: KMH	DWG. NO. G18A2033
SCALE: NTS	FIGURE 14
DATE: 01/27/21	

Figure 14: 320 Amp Meter Socket, Overhead Service

Service Size	Wire Sizes			
	Minimum		Recommended	
	Neutral*	Line	Neutral*	Line
320 Amp	2 - 4/0 Cu.	2 - 4/0 Cu.	2 - 4/0 Cu.	2 - 4/0 Cu.
	2 - 300 AL	2 - 300 AL	2 - 300 AL	2 - 300 AL

* Neutral may be reduced under specific conditions allowed by NEC.

Note:
This application for 120/208v, 3-wire service.

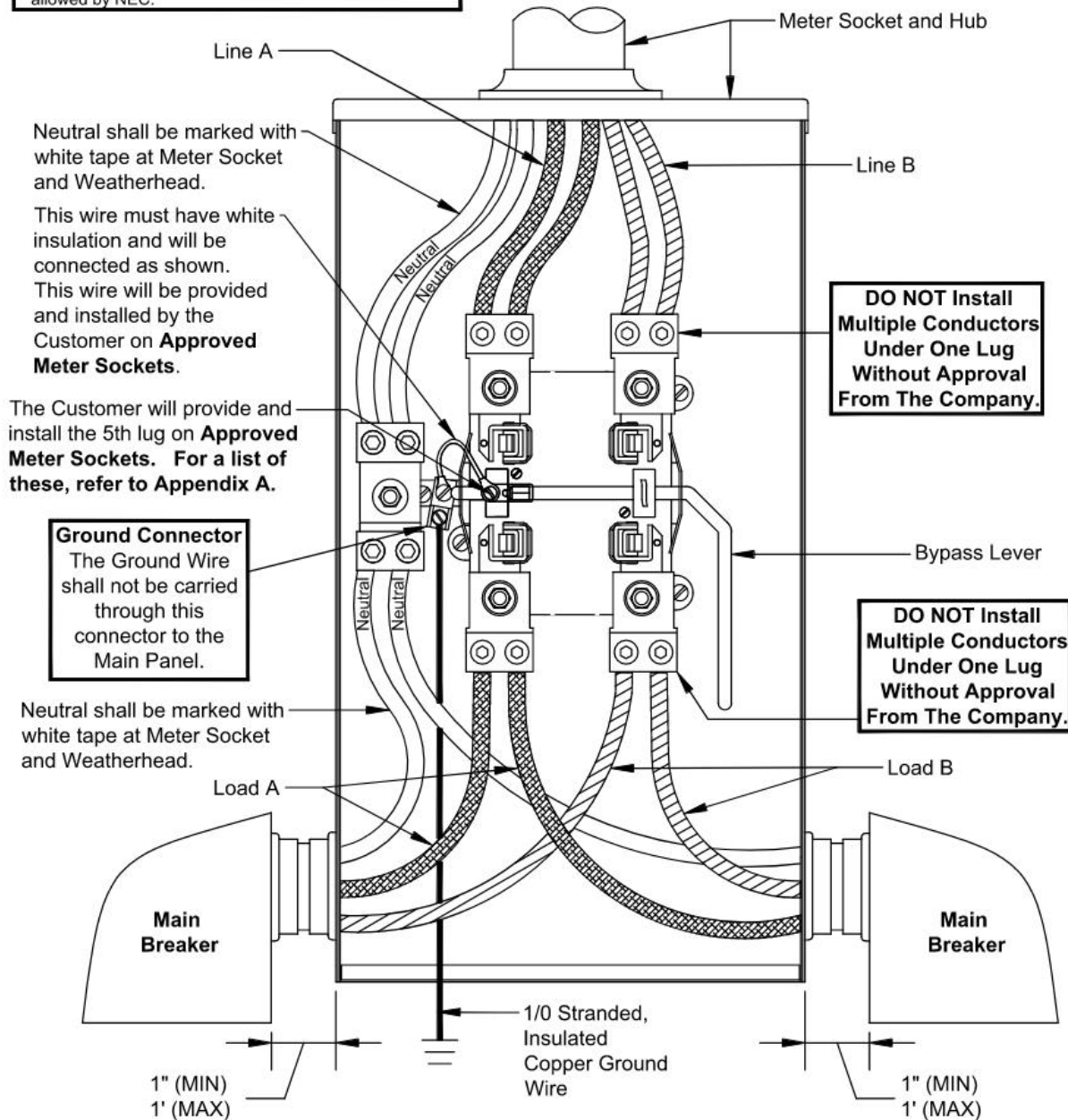

All Equipment Furnished and Installed By Customer Unless Otherwise Noted.

02/04/21	DER
01/27/21	LRS
06/11/20	SMS
REVISIONS	



320 Amp Meter Socket, Network (120/208), Overhead Service	
DRAWN: KMH	DWG. NO. G18A2033A
SCALE: NTS	FIGURE 14A
DATE: 01/27/21	

Figure 14A: 320 Amp Meter Socket, Network (120/208), Overhead Service

Service Size	Wire Sizes			
	Minimum		Recommended	
	Neutral*	Line	Neutral*	Line
320 Amp	2 - 4/0 Cu.	2 - 4/0 Cu.	2 - 4/0 Cu.	2 - 4/0 Cu.
	2 - 300 AL	2 - 300 AL	2 - 300 AL	2 - 300 AL

* Neutral may be reduced under specific conditions allowed by NEC.

DO NOT Install Multiple Conductors Under One Lug Without Approval From The Company.

DO NOT Install Multiple Conductors Under One Lug Without Approval From The Company.

All Equipment Furnished and Installed By Customer Unless Otherwise Noted.

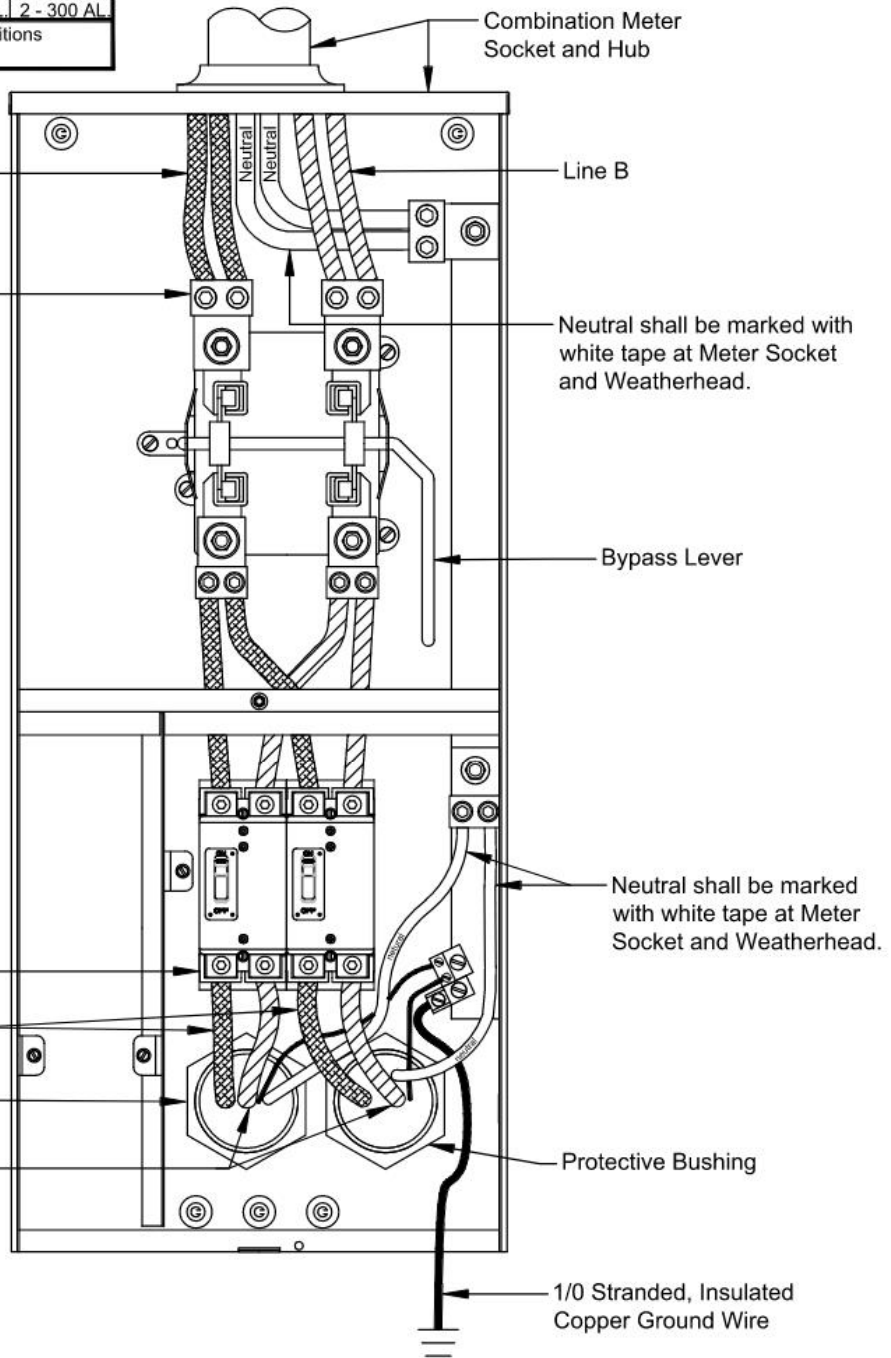

02/04/21 DER
07/01/19 KMH
REVISIONS



320 Amp Combination Meter Socket, Overhead Service	
DRAWN: SDS	DWG. NO. G18A2034
SCALE: NTS	FIGURE 15
DATE: 07/01/19	

Figure 15: 320 Amp Combination Meter Socket, Overhead Service

Service Size	Wire Sizes			
	Minimum		Recommended	
	Neutral*	Line	Neutral*	Line
320 Amp	2 - 4/0 Cu.	2 - 4/0 Cu.	2 - 4/0 Cu.	2 - 4/0 Cu.
	2 - 300 AL	2 - 300 AL	2 - 300 AL	2 - 300 AL

* Neutral may be reduced under specific conditions allowed by NEC.

Note:
This application for 120/208v, 3 wire service.

DO NOT Install Multiple Conductors Under One Lug Without Approval From The Company.

The Customer will provide and install the 5th lug on **Approved Meter Sockets**. For a list of these, refer to **Appendix A**.

This wire must have white insulation and will be connected as shown. This wire will be provided and installed by the Customer on **Approved Meter Sockets**.

DO NOT Install Multiple Conductors Under One Lug Without Approval From The Company.

All Equipment Furnished and Installed By Customer Unless Otherwise Noted.

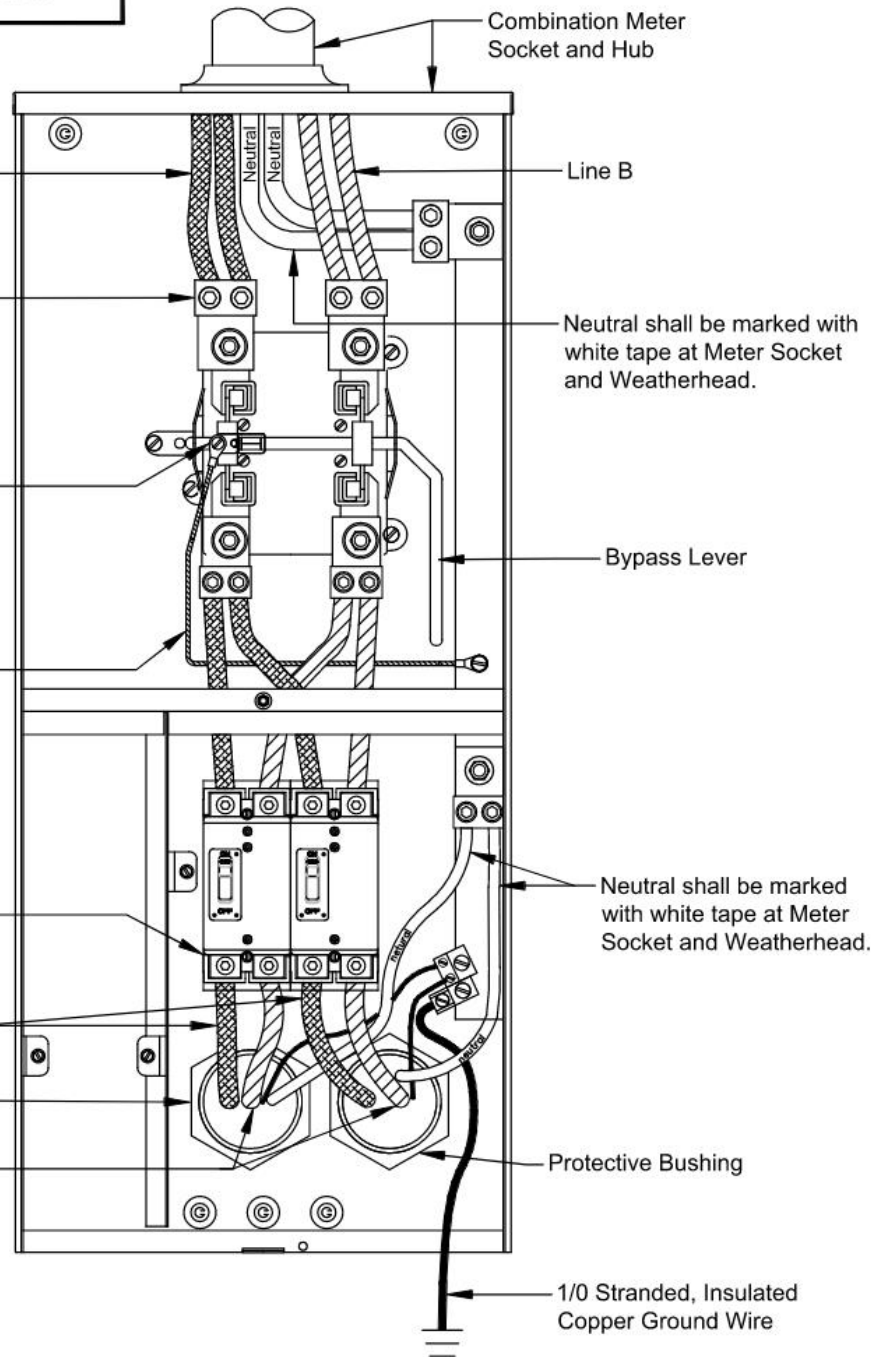

02/04/21 DER
 06/11/20 SMS
 REVISIONS



320 Amp Combination Meter Socket, Network (120/208), Overhead Service	
DRAWN: KMH	DWG. NO. G18A2034A
SCALE: NTS	FIGURE 15A
DATE: 07/01/19	

Figure 15A: 320 Amp Combination Meter Socket, Network (120/208), Overhead Service

Security Light May Be Leased From the Company. Customer will not be allowed to install their light on this pole.

The path to the Service Pole shall be clear of trees and building debris and materials.

Pole installed and owned **by the Company**.

This Weatherhead shall be located no more than 3' below the top of the Pole.

Two Hole Conduit Strap

Meter Loop (Weatherhead, Service Entrance Wire, Conduit, Meter Socket/Breaker Combination, Ground Wire, Ground Rod Clamp, 5/8" x 8' Ground Rod, Etc.) may be purchased from and installed by the Company on Company pole **ONLY**.

A minimum of 24" of wire shall be provided **by the Customer**. The Neutral shall be marked with white tape. The wire shall be marked or listed as Sunlight Resistant as per NEC 310.10 (D).

Attachment furnished and installed **by the Company**.

Drip-Loop 10' Clearance (Min.) above Finished Grade.

Service Drop Minimum Clearances	
12'	Above Sidewalks
16'	Above Residential Driveways
18.5'	Above Public Driveways, Alleys, Roads, and Other Areas Subject to Truck & Construction Traffic.

Meter Loop Will be Owned and Maintained by the Customer.

The Meter Pole shall be located within 30' of a Mobile Home/Building; Otherwise see NEC Article 550.32.

Note:
Meter Loop will not be installed on Primary Power Poles.

This may be a Meter Socket and separate Breaker Enclosure connected by Rigid Conduit.

No Bypass Lever Allowed.

4' To 6' Above Final Grade Level

Service Size	Ground Wire
100 Amp	#6 Cu.
200 Amp	#4 Cu.

Customer supplied and installed Underground Service Feeder.

Ground Wire

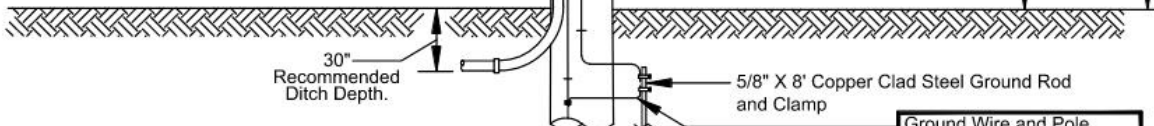

Ground Wire and Pole Down Ground are bonded together at the Ground Rod.

Service Size	Wire Sizes		Conduit Size	Wire Sizes		Conduit Size	Conduit Type ***
	Minimum	Line		Neutral**	Line		
100 Amp*	#4 Cu.	#4 Cu.	1 1/4"	#3 Cu.	#3 Cu.	1 1/4"	Galv. Rigid Steel
	#2 AL.	#2 AL.	1 1/4"	#1 AL.	#1 AL.	1 1/2"	Galv. Rigid Steel
200 Amp	2/0 Cu.	2/0 Cu.	2"	3/0 Cu.	3/0 Cu.	2"	Galv. Rigid Steel
	4/0 AL.	4/0 AL.	2"	250 AL.	250 AL.	2 1/2"	Galv. Rigid Steel

* 100 Amp allowed on overhead service only.
 ** Neutral May Be Reduced Under Specific Conditions Allowed By NEC.
 *** Other types of conduit allowed depending on local code.

All Equipment Furnished and Installed By Customer Unless Otherwise Noted.

02/04/21	DER
08/14/19	KMH
02-18-13	SDS
03-18-10	SDS
01-07-09	SDS
07-15-06	SDS
05-17-05	SDS
01-01-97	AMA
REVISIONS	



100/200 Amp Meter Pole, Underground Feeder

DRAWN: LU	DWG. NO. G18A2035
SCALE: NTS	FIGURE 16
DATE: 01/01/95	

Figure 16: 100/200 Amp Meter Pole, Underground Feeder

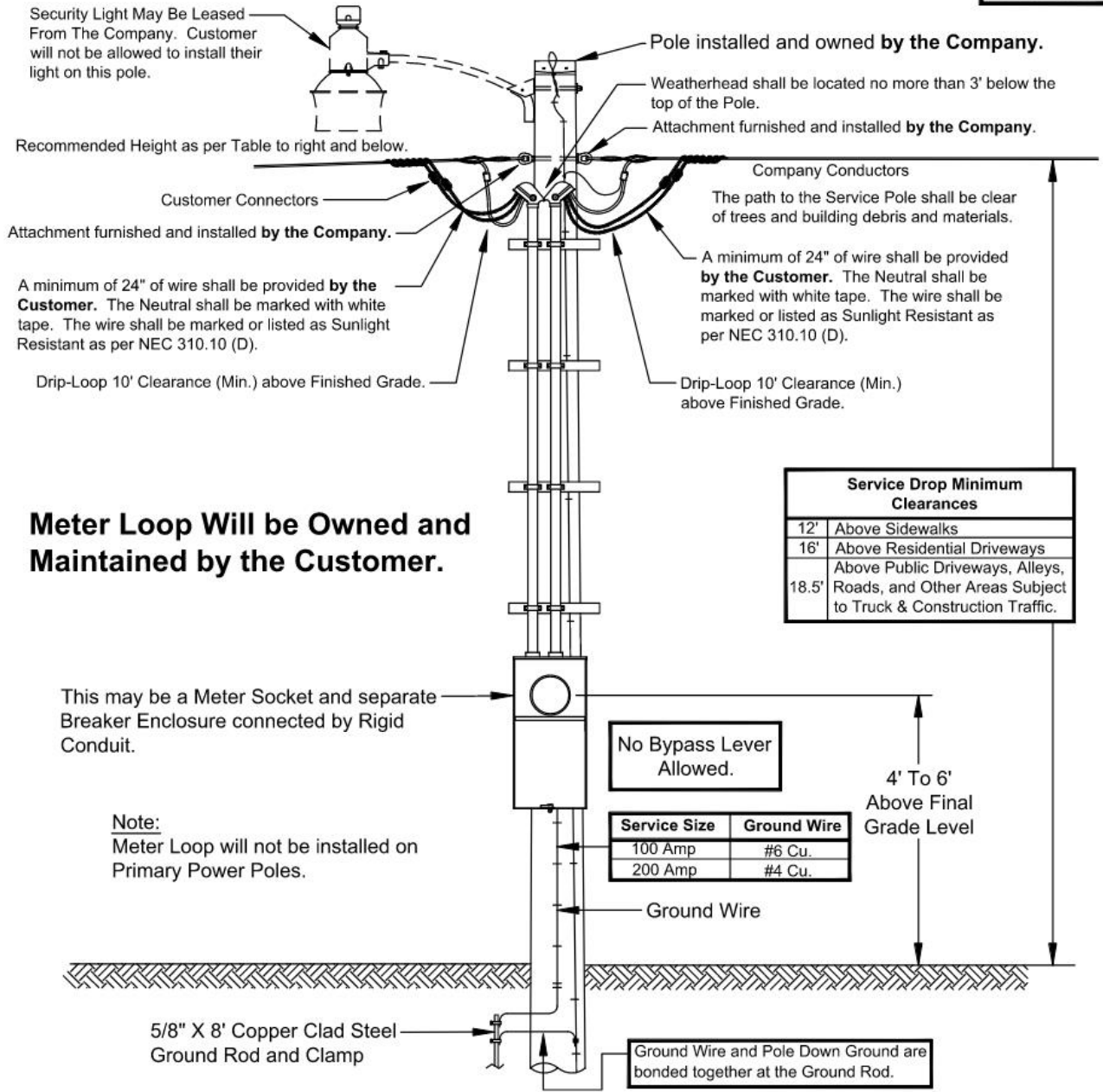

Service Drop Minimum Clearances	
12'	Above Sidewalks
16'	Above Residential Driveways
18.5'	Above Public Driveways, Alleys, Roads, and Other Areas Subject to Truck & Construction Traffic.

Service Size	Ground Wire
100 Amp	#6 Cu.
200 Amp	#4 Cu.

Service Size	Wire Sizes Minimum		Conduit Size	Wire Sizes Recommended		Conduit Size	Conduit Type ***
	Neutral**	Line		Neutral**	Line		
100 Amp*	#4 Cu.	#4 Cu.	1 1/4"	#3 Cu.	#3 Cu.	1 1/4"	Galv. Rigid Steel
	#2 AL.	#2 AL.	1 1/4"	#1 AL.	#1 AL.	1 1/2"	Galv. Rigid Steel
200 Amp	2/0 Cu.	2/0 Cu.	2"	3/0 Cu.	3/0 Cu.	2"	Galv. Rigid Steel
	4/0 AL.	4/0 AL.	2"	250 AL.	250 AL.	2 1/2"	Galv. Rigid Steel

* 100 Amp allowed on overhead service only.
 ** Neutral May Be Reduced Under Specific Conditions Allowed By NEC.
 *** Other types of conduit allowed depending on local code.

All Equipment Furnished and Installed By Customer Unless Otherwise Noted.

02/04/21	DER
08-14-19	KMH
01-06-09	SDS
07-15-06	SDS
05-17-05	SDS
01-01-97	AMA
REVISIONS	



100/200 Amp Meter Pole, Overhead Feeder	
DRAWN: LU	DWG. NO. G18A2036
SCALE: NTS	FIGURE 17
DATE: 01/01/95	

Figure 17: 100/200 Amp Meter Pole, Overhead Feeder

Security Light May Be Leased From The Company. Customer will not be allowed to install their light on this pole.

Pole installed and owned by the Company.

Attachment furnished and installed by the Company.

Weatherhead shall be located no more than 3' below the top of the Pole.

Note:
Meter Loop will not be installed on Primary Power Poles.

The path to the Service Pole shall be clear of trees and building debris and materials.

Company conductors

A minimum of 24" of wire shall be provided by the Customer. The Neutral shall be marked with white tape. The wire shall be marked or listed as Sunlight Resistant as per NEC 310.10 (D).

Drip-Loop 10' Clearance (Min.) above Finished Grade.

Two Hole Conduit Strap

Service Drop Minimum Clearances	
12'	Above Sidewalks
16'	Above Residential Driveways
18.5'	Above Public Driveways, Alleys, Roads, and Other Areas Subject to Truck & Construction Traffic.

Meter Loop, Meter Socket and Customer's Conduit Will Be Owned And Maintained By The Customer.

Customer's Conduit Will Be Owned And Maintained By The Customer.

Customer supplied and installed Underground Service Feeder. This service feeder will be enclosed in either schedule 80 electrical grade PVC or Rigid Galvanized Steel.

4' To 6' above Final Grade Level

1/0 Copper Ground Wire, This can be insulated and stranded.

30" Recommended Ditch Depth.

5/8" X 8' Copper Clad Steel Ground Rod and Clamp
Ground Wire and Pole Down Ground are bonded together at the Ground Rod.

Service Size	Wire Sizes		Conduit Size	Wire Sizes		Conduit Size	Conduit Type **
	Minimum			Recommended			
	Neutral*	Line		Neutral*	Line		
320 Amp	2-4/0 Cu.	2-4/0 Cu.	3"	2-4/0 Cu.	2-4/0 Cu.	3"	Galv. Rigid Steel
	2-300 AL.	2-300 AL.	4"	2-300 AL.	2-300 AL.	4"	Galv. Rigid Steel

* Neutral May Be Reduced Under Specific Conditions Allowed By NEC.
** Other types of conduit allowed depending on local code.

All Equipment Furnished and Installed By Customer Unless Otherwise Noted.

02/04/21	DER
09-04-19	KMH
02-18-13	SDS
01-06-09	SDS
07-15-06	SDS
05-17-05	SDS
06-25-03	WJE
REVISIONS	



320 Amp Meter Pole, Underground Feeder

DRAWN: LU	DWG. NO. G18A2037
SCALE: NTS	FIGURE 18
DATE: 07/01/97	

Figure 18: 320 Amp Meter Pole, Underground Feeder

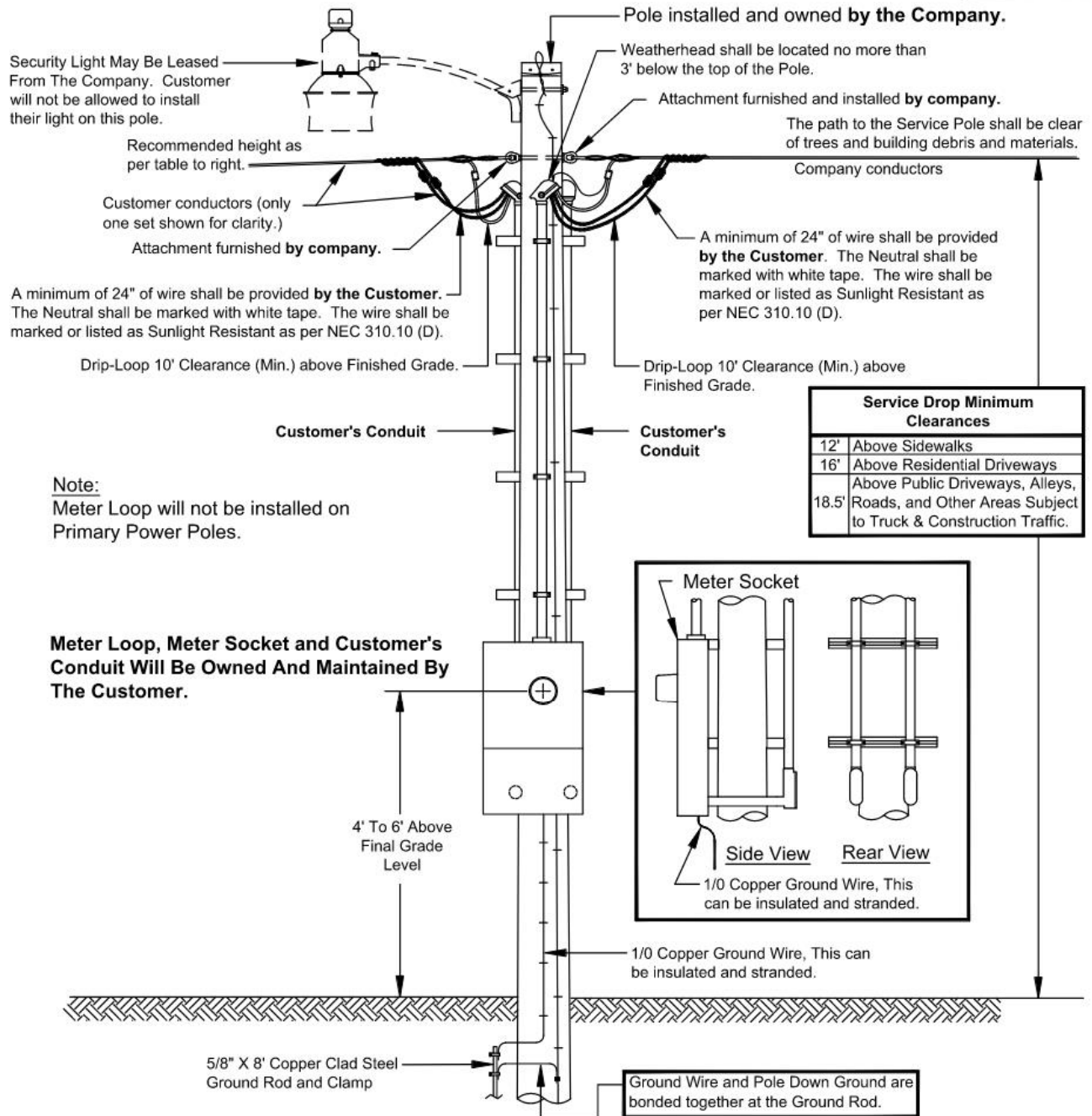

Note:
Meter Loop will not be installed on Primary Power Poles.

Meter Loop, Meter Socket and Customer's Conduit Will Be Owned And Maintained By The Customer.

Service Drop Minimum Clearances	
12'	Above Sidewalks
16'	Above Residential Driveways
18.5'	Above Public Driveways, Alleys, Roads, and Other Areas Subject to Truck & Construction Traffic.

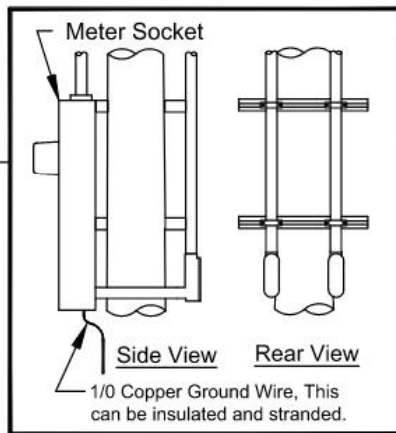

Service Size	Wire Sizes		Conduit Size	Wire Sizes		Conduit Size	Conduit Type **
	Minimum	Line		Recommended	Neutral*		
320 Amp	2-4/0 Cu.	2-4/0 Cu.	3"	2-4/0 Cu.	2-4/0 Cu.	3"	Galv. Rigid Steel
	2-300 AL.	2-300 AL.	4"	2-300 AL.	2-300 AL.	4"	Galv. Rigid Steel

* Neutral May Be Reduced Under Specific Conditions Allowed By NEC.
** Other types of conduit allowed depending on local code.

All Equipment Furnished and Installed By Customer Unless Otherwise Noted.

02/04/21	DER
09-04-19	KMH
01-06-09	SDS
07-15-06	SDS
07-15-05	SDS
REVISIONS	



320 Amp Meter Pole, Overhead Feeder

DRAWN: LU	DWG. NO. G18A2038
SCALE: NTS	FIGURE 19
DATE: 07/01/97	

Figure 19: 320 Amp Meter Pole, Overhead Feeder

6.3 MULTIPLE METERS, SINGLE PHASE OVERHEAD SERVICE

A. General Notes:

1. If more than six meters are required, consult the Company for approval of equipment prior to purchase.
2. Service entrance conductors, 5/8" x 8' copper clad steel ground rod, ground rod clamp, ground wire, conduit, conduit straps, weatherhead, lock nuts, bushings, meter socket assembly, meter socket assembly hub, service drop attachment device, and miscellaneous mounting hardware furnished and installed by the Customer.
3. Meters, service connectors, and service drop furnished and installed by Company.
4. The meter socket assembly should be "readily accessible" (see definitions). The Company requires a level and unobstructed workspace of 78 inches tall, 18 inches on either side, and 48 inches in front of the meter socket assembly. Prior approval is required for placement of the meter socket assembly in alleyways or areas where it may be subjected to damage.
5. If the Company is required to attach the service drop directly to the Customer's meter loop conduit, the Customer shall install a steel service mast.
6. The meter sockets shall meet the following specifications:
 - a. The latest revision of U.L. 414 and ANSI C12.7 Standards.
 - b. Must be U.L. listed.
 - c. Must have grounding connector for triplex.
 - d. Lug size – 2/0 minimum.
 - e. On 120/208v services, the customer must provide the meter socket with 5th lug installed in the 9 o'clock position.
 - f. **See Appendix A for list of approved meter sockets.**

B. Mounting:

1. Meter socket, ground wire, and conduit shall be surface mounted and securely fastened to the structure. The meter socket shall be installed in a level and plumb position. **Flush mounted or recessed metering equipment and service riser conduit embedded in a wall will not be permitted.**
2. Where the exterior wall is other than brick or concrete blocks, a supporting frame shall be installed behind the exterior wall to provide a solid mounting surface for the meter socket.
3. Meter sockets, metering cabinets, and conduit straps shall be installed with the following:
 - a. Lead anchors or double helix concrete screws shall be used with brick or solid concrete surfaces.
 - b. Toggle bolts shall be used with other masonry siding.
 - c. Wood screws shall be used with solid wood surfaces.
 - d. All mounting hardware shall be minimum #12(1/4") corrosion resistant screws.
 - e. A minimum of 4 fasteners shall be used to install any socket or cabinet unless specifically stated otherwise.
4. An intersystem bonding termination bar shall be installed to facilitate the connection of other utility's ground to a common ground. The location of this device shall be located directly below the meter socket or meter combination socket.
 - a. **See Appendix A for list of approved intersystem bonding termination bars.**
5. Wire not enclosed in conduit shall be a minimum of 36 inches away from any window or door opening.

C. Connections:

1. The Customer is responsible for termination of the incoming wiring if the wire terminates in a main breaker or fuse holder. The Company will terminate the incoming wire if it terminates on bus bar terminals. The main breaker will be removed when the service wire is being pulled by the Company.
2. Do not score line or load wire when removing insulation.
3. The Customer shall use wire brush or sandpaper to clean all conductors, apply a non-grit type inhibitor and tighten to manufacturer's specifications.

D. Meter Socket Marking:

1. **Before the meters are installed, each socket position and corresponding building unit, i.e. apt number or letter, Suite number or letter, tenant number or letter, or physical address served shall be accurately, clearly, and permanently labeled with an engraved plaque. See the figures for proper location. These shall be screwed, bolted or riveted to the equipment. If the equipment is marked incorrectly, the customer shall be responsible for all costs incurred by Liberty for correcting the meter socket identification. Please note that marker ink or adhesive labels are examples of non-permanent labeling.**
2. **Letters or numbers on the engraved plaque shall be a minimum of one (1) inch in height of contrasting color, i.e., black and white, red and green, orange and blue, etc.**

E. Conductor Marking:

All neutral conductors shall be clearly marked with white tape at the point of delivery and at the meter socket assembly.

Service Size	Wire Sizes		Conduit Size	Wire Sizes		Conduit Size	Conduit Type
	Minimum Neutral*	Line		Recommended Neutral*	Line		
2-100 Amp	2/0 Cu.	2/0 Cu.	2"	3/0 Cu.	3/0 Cu.	2"	Galv. Rigid Steel
	4/0 AL.	4/0 AL.	2"	250 AL.	250 AL.	2 1/2"	Galv. Rigid Steel
2-200 Amp	2-4/0 Cu.	2-4/0 Cu.	3"	2-4/0 Cu.	2-4/0 Cu.	3"	Galv. Rigid Steel
	2-300 AL.	2-300 AL.	4"	2-300 AL.	2-300 AL.	4"	Galv. Rigid Steel

* Neutral May Be Reduced Under Specific Conditions Allowed By NEC.

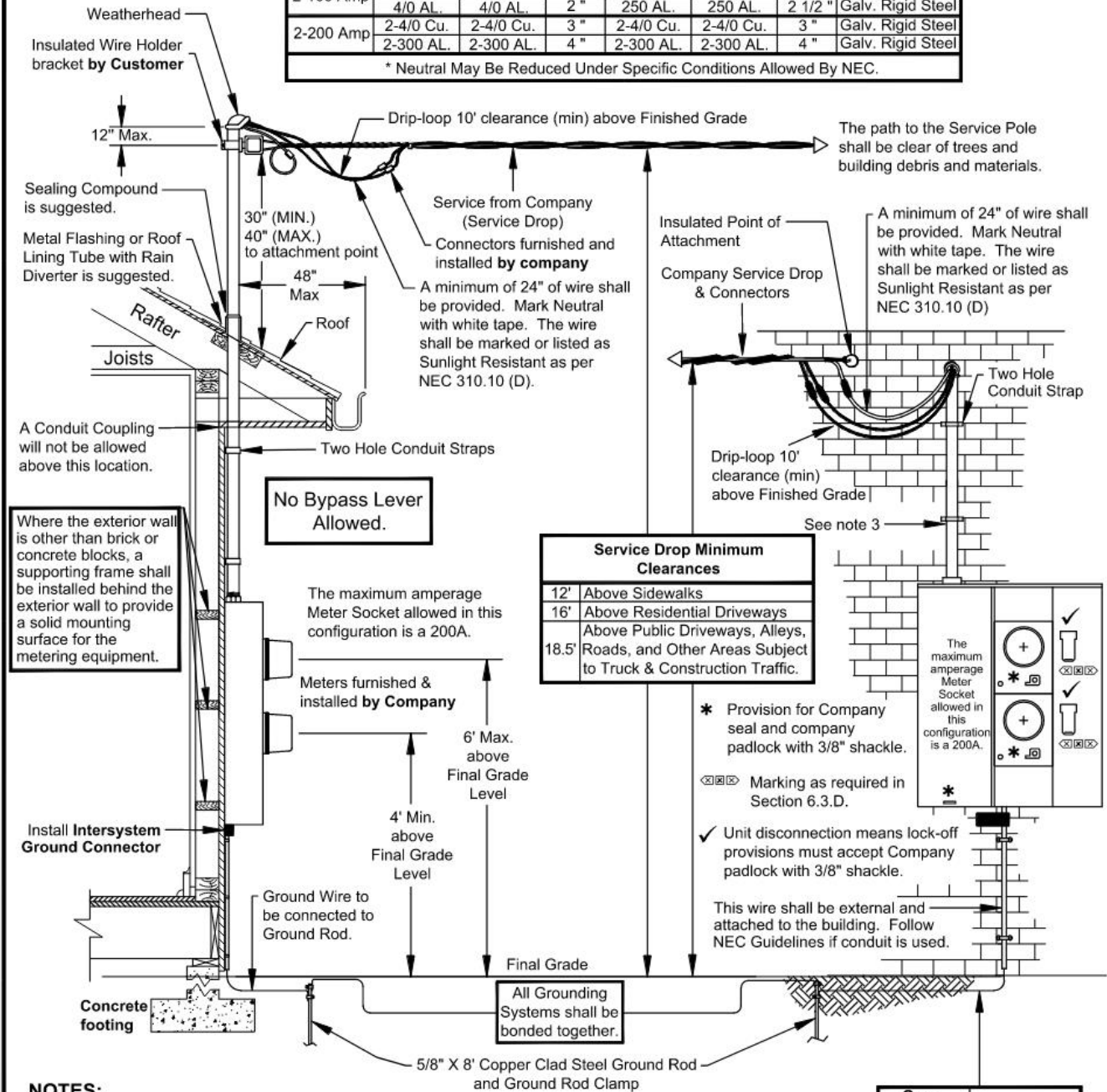

No Bypass Lever Allowed.

Service Drop Minimum Clearances	
12'	Above Sidewalks
16'	Above Residential Driveways
18.5'	Above Public Driveways, Alleys, Roads, and Other Areas Subject to Truck & Construction Traffic.

Gang Metering	Ground Wire
2-100 Amp	#4 Cu
2-200 Amp	1/0 Cu

NOTES:

1. If minimum vertical clearance cannot be maintained with the installation of an attachment bolt as shown above, the Customer shall install a Steel Service Mast as shown directly above left.
2. Connections between Service Drop and Service Entrance Conductors shall be made by Company personnel below Weatherhead, forming a Drip Loop.
3. Other Types of conduit may be allowed depending on Local Code Requirements. These may include EMT, Electrical Grade (schedule 80) PVC, and Rigid Aluminum. However, the Service Drop shall not be attached to any of these.

All Equipment Furnished and Installed By Customer Unless Otherwise Noted.

02/04/21	DER
01-23-20	SMS
08-26-19	KMH
07-15-06	SDS
05-17-05	SDS
REVISIONS	



Wiring of two Meters, Overhead Service	
DRAWN: LU	DWG. NO. G18A2039
SCALE: NTS	FIGURE 20
DATE: 01/01/95	

Figure 20: Wiring of Two Meters, Overhead Service

A minimum of 24" of wire shall be provided. Mark Neutral with white tape. The wire shall be marked or listed as Sunlight Resistant as per NEC 310.10 (D).

The path to the Service Pole shall be clear of trees and building debris and materials.

Company Service Drop & Connectors

Insulated Point of Attachment

Drip-loop 10' clearance (min) above Finished Grade

The number, type, and size of conduits will vary with each installation. Contact Liberty for more information.

Service Drop Minimum Clearances	
12'	Above Sidewalks
16'	Above Residential Driveways
18.5'	Above Public Driveways, Alleys, Roads, and Other Areas Subject to Truck & Construction Traffic.

Number of conduits may vary depending on service requirements.

Two Hole Conduit Strap

Where the exterior wall is other than brick or concrete blocks, a supporting frame shall be installed behind the exterior wall to provide a solid mounting surface for the metering equipment.

No Bypass Lever Allowed.

* Provision for Company seal and company padlock with 3/8" shackle.

☒☒☒ Marking as required in Section 6.3.D.

✓ Unit disconnection means lock-off provisions must accept Company padlock with 3/8" shackle.

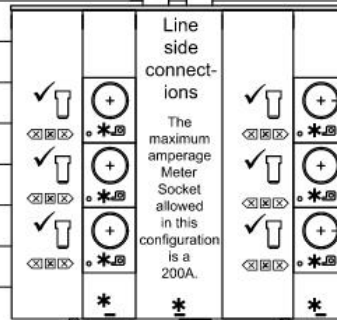

Either install a #6 copper wire (Minimum) from the same connection point as the main Copper Ground Wire connection in the multi-meter incoming compartment or the ground rod to **Intersystem Ground Connector**.

Main Copper Ground Wire as per NEC. This wire shall be external and attached to the building. Follow NEC Guidelines if conduit is used.

6' Max. above Final Grade

3' Min. above Final Grade

A minimum of one 5/8" X 8' Copper Clad Steel Ground Rod shall be provided by **Customer**. However, more than one Ground Rod may be needed. Consult NEC for requirements.

All Grounding Systems shall be bonded together.

Notes:

1. If minimum vertical clearance cannot be maintained with the installation of an attachment point as shown above, contact the Company for requirements.
2. Connections between Service Drop and Service Entrance Conductors shall be made by Company personnel below Weatherhead, forming a Drip Loop.
3. Service Entrance Conductors shall be sized as per NEC

If more than 6 meters are required, please contact the Company for configuration. As a minimum, Liberty will require the riser diagram and cut sheets as proposed by the Electrical Engineer.

All Equipment Furnished and Installed By Customer Unless Otherwise Noted.

02/04/21	DER
08-26-19	KMH
03-18-10	SDS
07-15-06	SDS
05-17-05	SDS
REVISIONS	



Three to Six Meters, Overhead Service

DRAWN: LU	DWG. NO. G18A2040
SCALE: NTS	FIGURE 21
DATE: 01/01/95	

Figure 21: Three to Six Meters, Overhead Service

7.0 UNDERGROUND SERVICES

7.1 GENERAL INFORMATION

1. PLEASE CONTACT THE COMPANY BEFORE PLANNING FOR AN UNDERGROUND SERVICE.

2. MINIMUM CLEARANCES OF SERVICE LATERALS IN CONDUIT

Horizontal from gas, water, and sewer lines.....	5 feet
Horizontal from telephone or cable television lines.....	1 foot
Horizontal to any structures (including footings and foundations).....	5 feet
Horizontal from conductor to edge of swimming pool	10 feet

(This is for either an above ground or in ground swimming pool)

Note: If within ten feet of service point, this clearance does not apply to structures served.

3. Help avoid the need for future trimming by planting trees and shrubs in the right place.

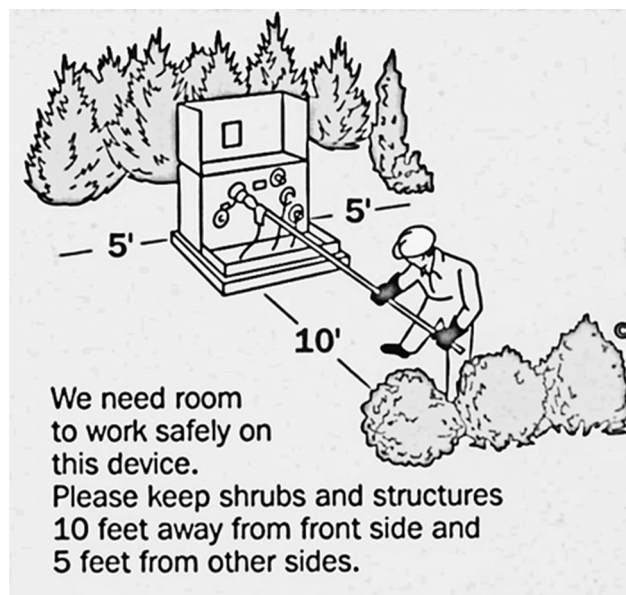

4. The service lateral shall not cross a sewer lateral field.

5. The Customer shall request the Company to designate the location of the point of delivery for each service location before construction is started.

6. Before doing any excavation, contact all Utilities to locate their underground facilities. The following are the One Call numbers for each state listed.

Missouri	(800) 344 – 7483
Kansas	(800) 344 – 7233
Arkansas	(800) 482 – 8998
Oklahoma	(800) 522 – 6543

7. The Customer will be held responsible to locate and mark all privately owned (Customer's or others) underground facilities.

8. Guard Posts maybe required on any underground service installation to protect the Company's Equipment. Contact the Company for requirements.

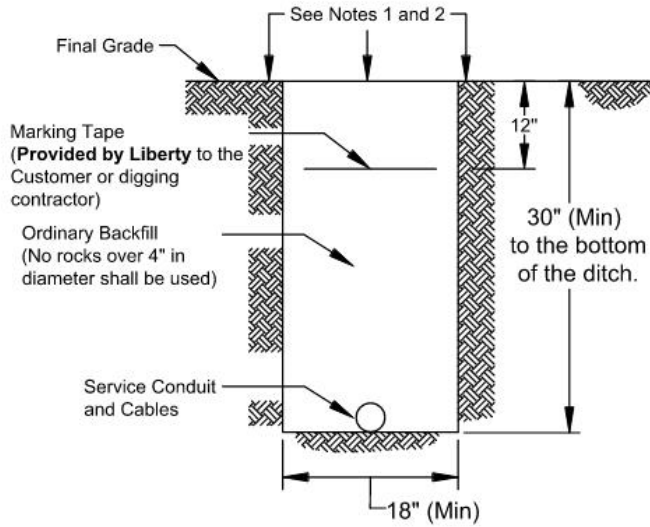

Ditch Profile

Caution!
Contact all Utilities
before digging

NOTES:

1. Backfill shall be compacted with the wheels of the excavation equipment or by other suitable means prior to final backfilling. The top of the backfilled trench shall be approximately level with the surrounding grade. Excess soil shall be hauled away. Final backfilling and cleanup shall not be done during adverse weather conditions.
2. An area on each side of the trench will be disturbed by the trenching, backfilling and cleanup operations. The area shall be leveled with the surrounding grade and cleanup, and it is the responsibility of the property owner to replant it with grass and to do any future landscaping that might be needed.

Service is provided as line of sight from Meter Socket location to service source. If the service route differs from this due to obstructions or terrain or is longer than 100 feet, **contact Liberty for requirements. Additional cost may apply.**

The Company will provide and install the conduit system for a fee from a point four foot away from the structure.

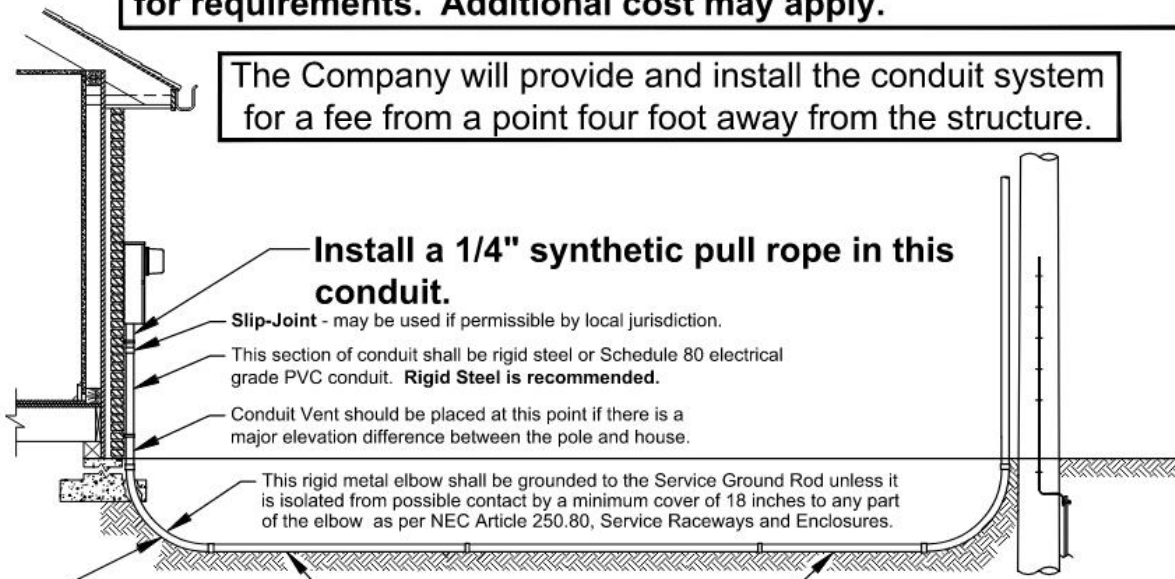

!!!! WARNING !!!!
If this elbow is not supported or if the soil under it is not well compacted, the conduit may pull out of the meter socket resulting in a possible failure of the service.

DO NOT USE WHITE WATER PIPE.

This denotes undisturbed earth.

If the Customer digs the ditch, a Ditch Inspection is REQUIRED. Contact the Company to schedule an inspection.

02/04/21	DER
06-21-19	KMH
04-01-09	SDS
05-17-05	SDS
REVISIONS	



Underground Service Detail	
DRAWN: SDS	DWG. NO. G18A2041
SCALE: NTS	FIGURE 22
DATE: 06/06/03	

Figure 22: Underground Service Detail

**Caution !
Contact all Utilities
before digging**

**The Company will provide and install the conduit system
for a fee from a point four foot away from the structure.**

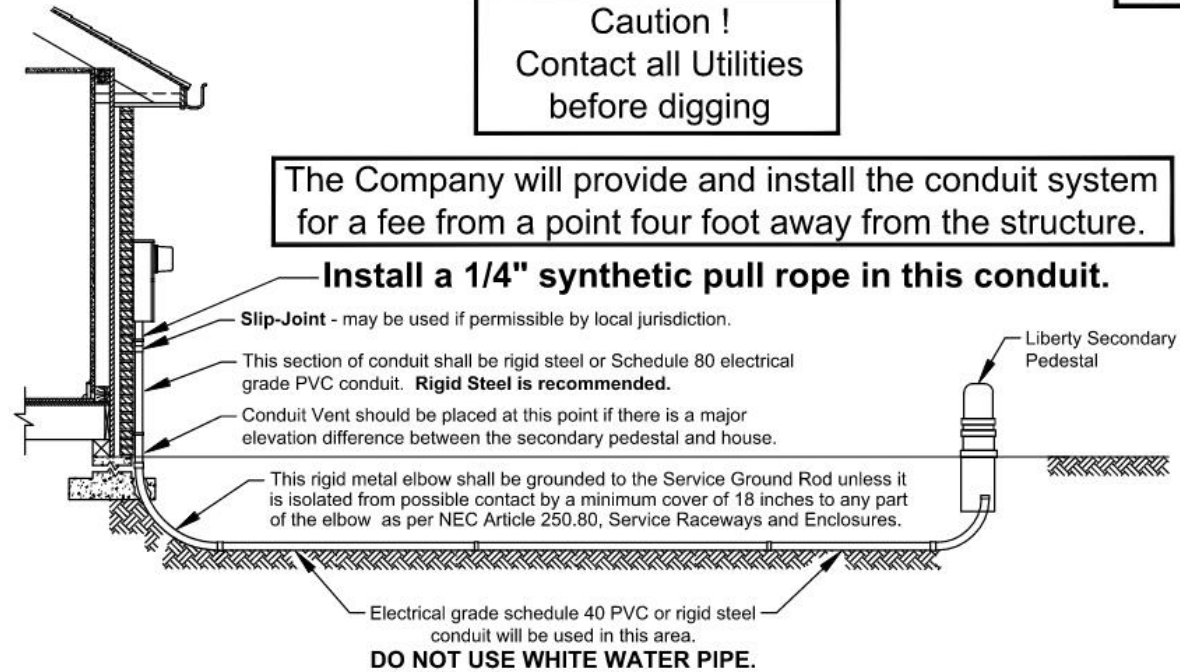

Service is provided as line of sight from Meter Socket location to service source. If the service route differs from this due to obstructions or terrain or is longer than 100 feet, contact Liberty for requirements. Additional cost may apply.

**The Company will provide and install the conduit system
for a fee from a point four foot away from the structure.**

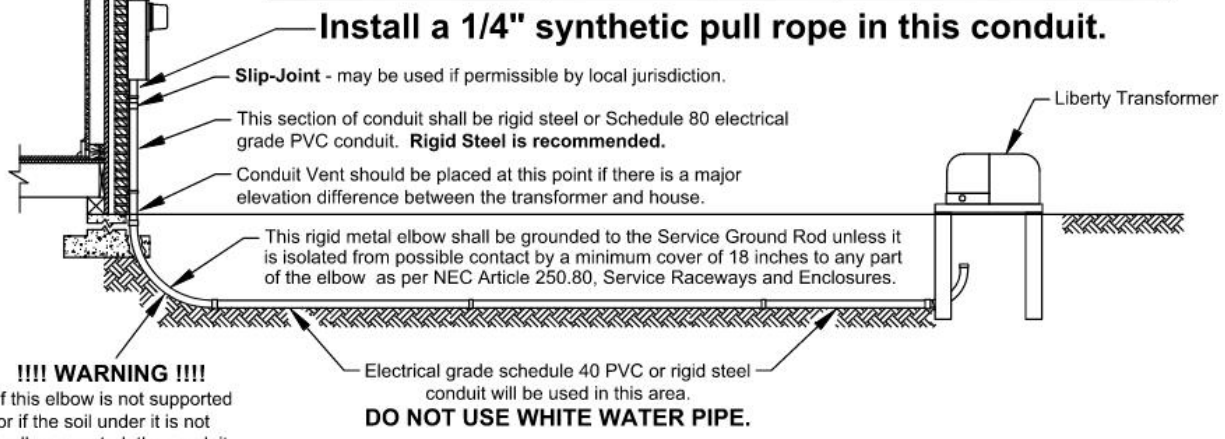

!!!! WARNING !!!!
If this elbow is not supported or if the soil under it is not well compacted, the conduit may pull out of the meter socket resulting in a possible failure of the service.

This denotes undisturbed earth.

If the Customer digs the ditch, a Ditch Inspection is REQUIRED. Contact the Company to schedule an inspection.

02/04/21	DER
07-10-19	KMH
04-01-09	SDS
REVISIONS	



Underground Service Detail (Continued)	
DRAWN: SDS	DWG. NO. G18A2042
SCALE: NTS	FIGURE 23
DATE: 07/15/06	

Figure 23: Underground Service Detail (Continued)

Service Equipment shall be installed as shown in these Service Standards. Install this equipment on front side of this structure.

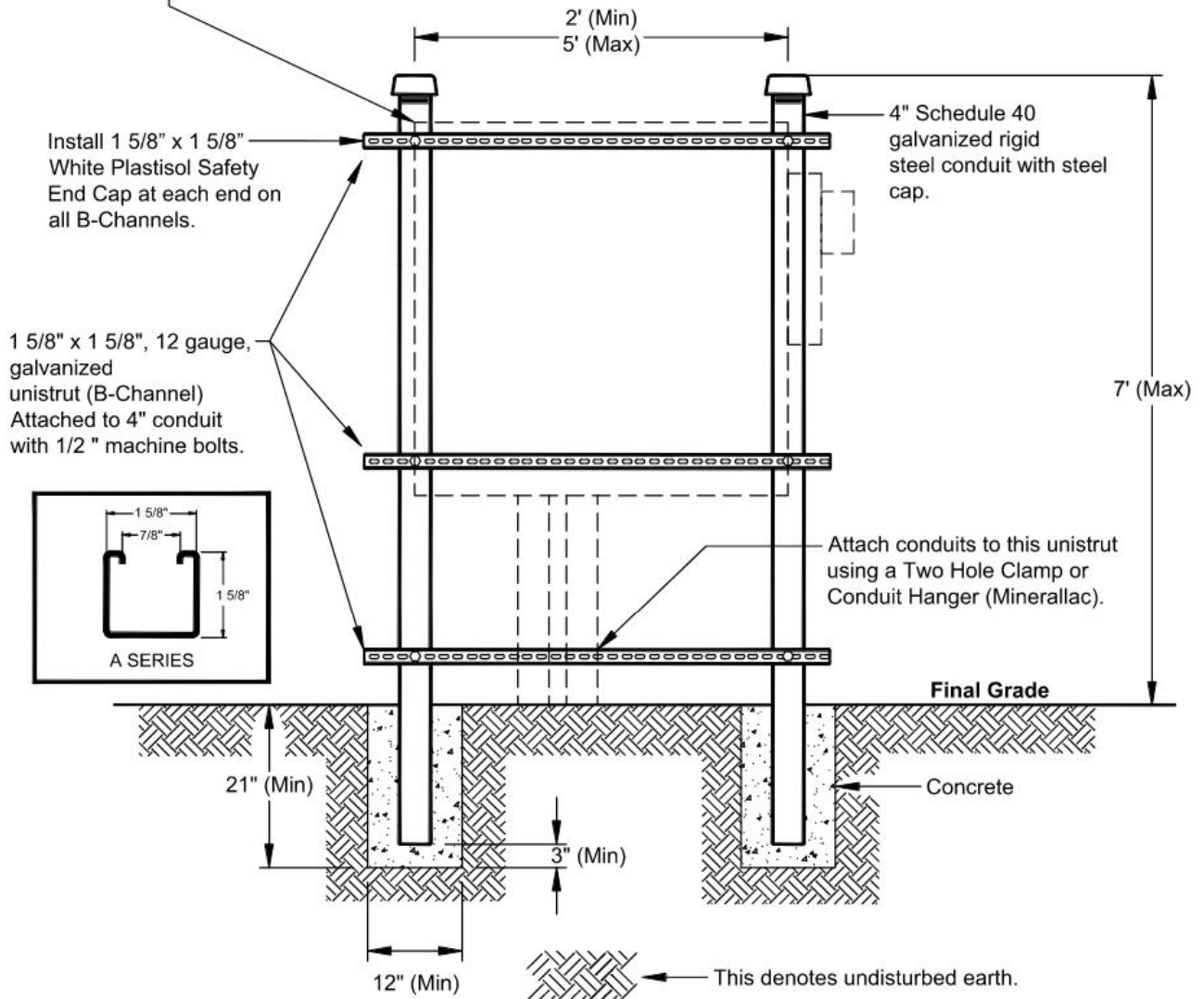

Contact Liberty for location, orientation, and/or verification before installing this structure.

Caution!
Contact all Utilities before digging

All Equipment Furnished & Installed By Customer Unless Otherwise Noted.

02/04/21 DER
06/21/19 KMH
REVISIONS



Underground Service Structure	
DRAWN: SDS	DWG. NO. G18A2043
SCALE: NTS	FIGURE 24
DATE: 07/15/06	

Figure 24: Underground Service Structure

7.2 200 AMP AND 320 AMP SINGLE PHASE UNDERGROUND SERVICE

A. General Notes:

1. Service entrance conductors, 5/8" x 8' copper clad steel ground rod, ground rod clamp, ground wire, conduit, conduit straps, lock nuts, bushings, 200 amp meter socket, hub closing plate, and miscellaneous mounting hardware furnished and installed by Customer.
2. Meter and service lateral conductors furnished and installed by Company.
3. The meter socket should be "readily accessible" (see definitions). The Company requires a level and unobstructed workspace of 78 inches tall, 18 inches on either side, and 48 inches in front of the meter socket. Prior approval is required for placement of the meter socket in alleyways or areas where it may be subjected to damage.
4. The 200 amp and 320 amp meter sockets shall meet the following specifications:
 - a. The latest revision of U.L. 414 and ANSI C12.7 Standards.
 - b. Must be U.L. listed.
 - c. Must have grounding connector for triplex.
 - d. Lug size – 2/0 minimum.
 - e. On 120/208v services, the customer must provide the meter socket with 5th lug installed in the 9 o'clock position.
 - f. See Appendix A for list of approved meter sockets.**
5. Conduit system shall be installed as per Figure 22 or 23.

B. Mounting:

1. Meter socket, ground wire, and conduit shall be surface mounted and securely fastened to the exterior structure. The meter socket shall be installed in a level and plumb position. **Flush mounted or recessed metering equipment and service lateral conduit embedded in a wall will not be permitted.**
2. Where the exterior wall is other than brick or concrete blocks, a frame shall be installed behind the exterior wall to provide a solid mounting surface for the meter socket.
3. Meter sockets, metering cabinets, and conduit straps shall be installed with the following:
 - a. Lead anchors or double helix concrete screws shall be used with brick or solid concrete surfaces.
 - b. Toggle bolts shall be used with other masonry siding.
 - c. Wood screws shall be used with solid wood surfaces.
 - d. All mounting hardware shall be minimum #12(1/4") corrosion resistant screws.
 - e. A minimum of 4 fasteners shall be used to install any socket or cabinet unless specifically stated otherwise.
4. An intersystem bonding termination bar shall be installed to facilitate the connection of other utility's ground to a common ground. The location of this device shall be located directly below the meter socket or meter combination socket.
 - a. See Appendix A for list of approved intersystem bonding termination bars.**

5. If PVC is used for the conduit attached to the meter socket, the rigid metal elbow shall be grounded/bonded to the service ground rod unless it is isolated from possible contact by a minimum cover of 18 inches to any part of the elbow as per NEC Article 250.80, Service Raceways and Enclosures.

a. See Appendix A for list of approved grounding clamps.

6. For 200 amp service, a minimum of two inch (2") galvanized rigid steel or electrical grade Schedule 80 PVC conduit shall be furnished and installed by Customer as shown in Figure 25.

7. For 320 amp service, a minimum of three inch (3") galvanized rigid steel or electrical grade Schedule 80 PVC conduit shall be furnished and installed by Customer as shown in Figure 25.

C. Connections:

1. Do not score load wire when removing insulation.

2. The Customer shall use wire brush or sandpaper to clean all conductors, apply a non-grit type inhibitor and tighten to manufacturer's specifications.

D. Conductor Marking:

All neutral conductors shall be clearly marked with white tape at the meter socket.

Ground Rod and Wire **MUST be Installed and Ground Wire **MUST** be attached to the structure before Service will be Connected.**

The required Meter Socket and Disconnect or Combination Meter Socket shall be located on the exterior of the structure and furnished **by the Customer**. When a disconnect is used, it shall not be closer than 1" nor farther away than 1' from the meter socket. If more than one disconnect is required, they shall be placed at the same location. A 200 amp combination socket is shown.

Meter furnished and installed **by Company**

Bypass Lever allowed on 320 amp meter socket only.

Install Intersystem Ground Connector

Slip-Joint may be used if permissible by local jurisdiction.

Service Size	Ground Wire
200 Amp	#4 Cu.
320 Amp	1/0 Cu.

This wire shall be external and attached to the building. Follow NEC Guidelines if Conduit is used

Service Size	Conduit Size	Recommended Conduit Type
200 Amp	2"	Galvanized Rigid Steel
320 Amp	3"	Galvanized Rigid Steel

Note: Sch 80 electrical grade PVC may be used.

4' to 6' Above Final Grade Level

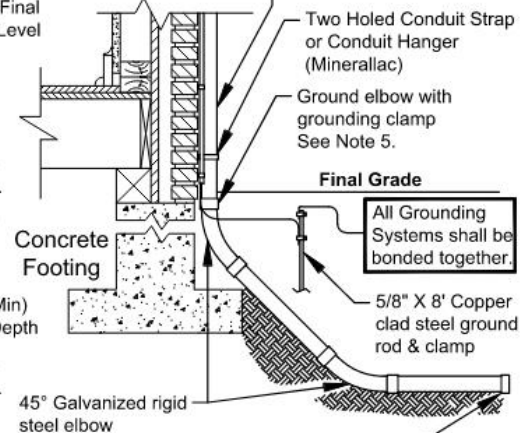
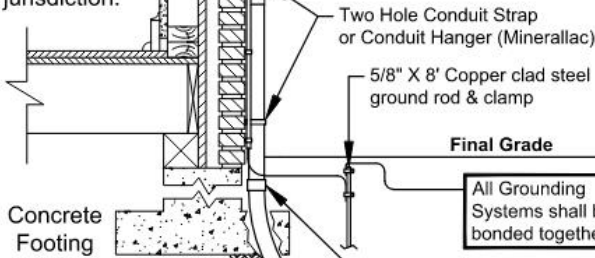

Sweep ell min. radius	
Conduit Size	Radius
2"	9.5"
3"	13"

Note: Galvanized Rigid Steel

Preferred

Alternate

Caution!
Contact all Utilities before digging

!!!! WARNING !!!!

If this elbow is not supported or if the soil under it is not well compacted, the conduit may pull out of the meter socket resulting in a possible failure of the service.



This denotes undisturbed earth.

Notes:

1. If a conduit reducer is used, it must be located immediately below the Meter Socket.
2. Line of Sight installation is required. See Definitions.
3. A conduit vent may be needed depending on the service arrangement and terrain.
4. If the service route is longer than 100 feet, contact Liberty for conduit requirements.
5. A metal elbow that is installed in an underground installation of rigid nonmetallic conduit and is isolated from possible contact by a minimum cover of 18 inches to any part of the elbow shall not be required to be grounded as per NEC Article 250.80, Service Raceways and Enclosures.

All Equipment Furnished & Installed By Customer Unless Otherwise Noted.

02-04-21	KMJ
06-29-19	KMH
04-01-09	SDS
07-15-06	SDS
05-17-05	SDS
01-01-97	AMA
REVISIONS	



200/320 Amp
Underground Service

DRAWN: LU	DWG. NO. G18A2044
SCALE: NTS	FIGURE 25
DATE: 01/01/95	

Figure 25: 200/320 Amp Underground Service

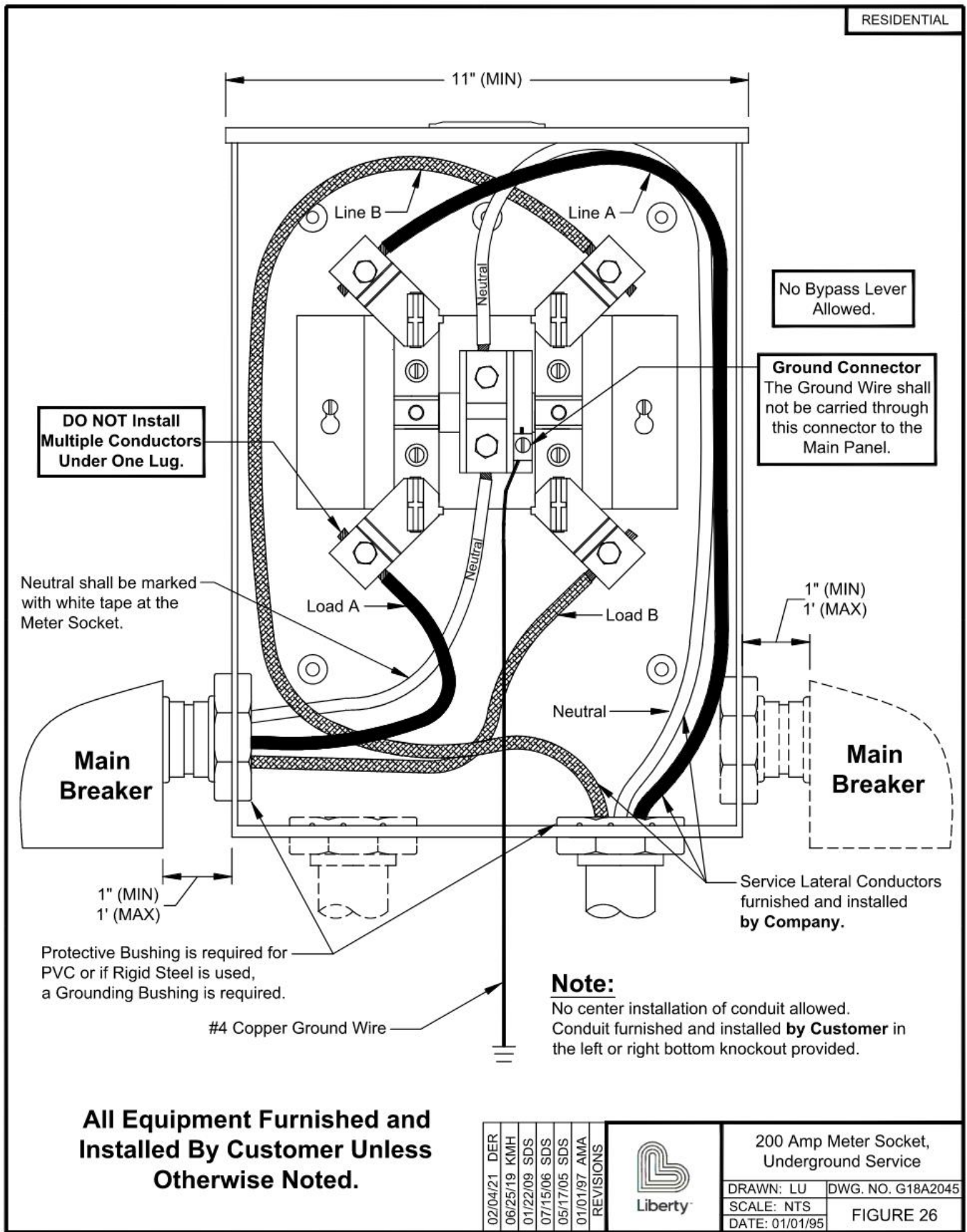
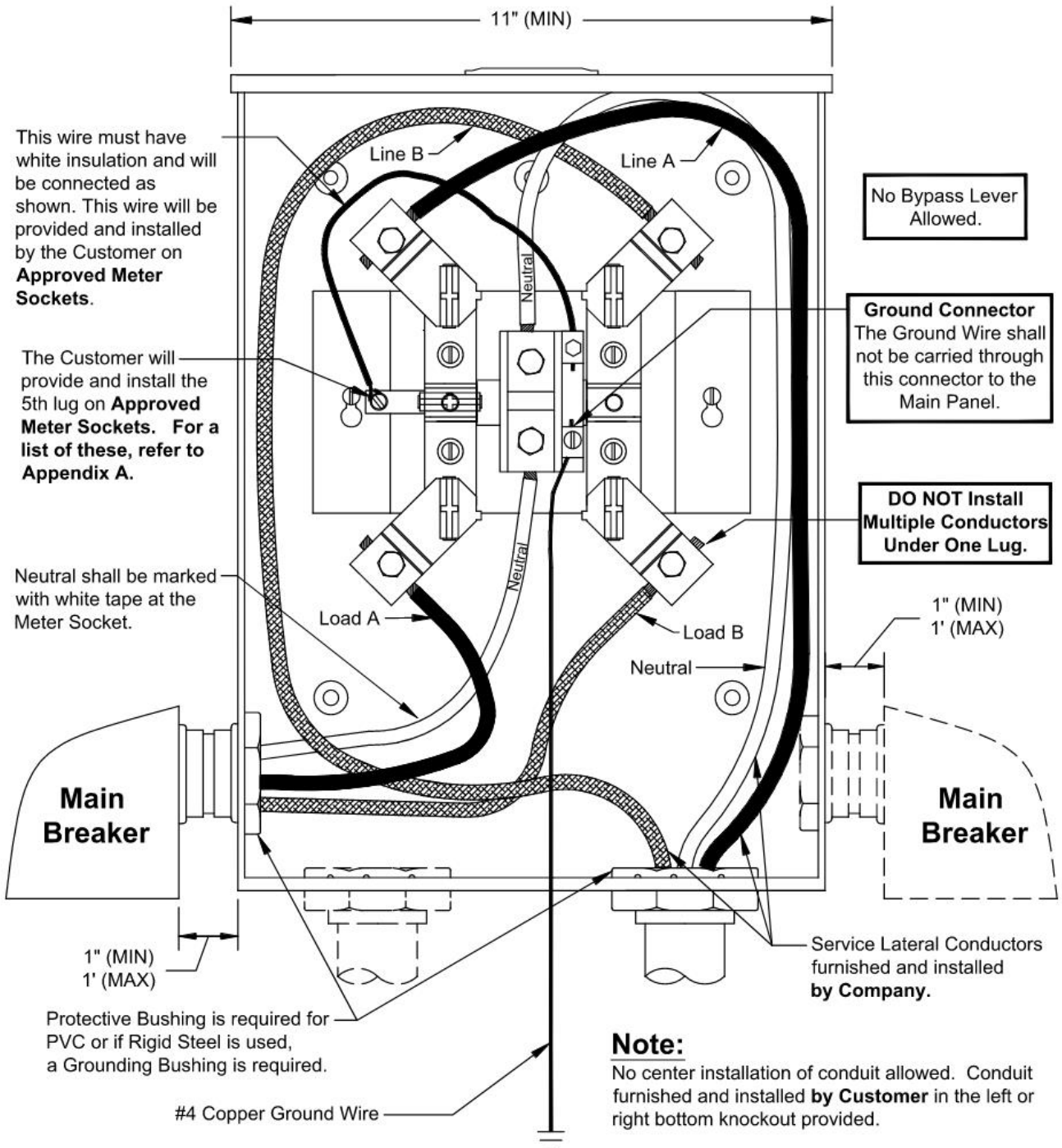

Figure 26: 200 Amp Meter Socket, Underground Service

Note:
This application for 120/208v, 3 wire service.



All Equipment Furnished and Installed By Customer Unless Otherwise Noted.

02/04/21	DER
07/15/19	KMH
01/22/09	SDS
07/15/06	SDS
05/17/05	SDS
REVISIONS	



200 Amp Meter Socket, Network (120/208), Underground Service

DRAWN: LU	DWG. NO. G18A2046
SCALE: NTS	FIGURE 27
DATE: 01/01/95	

Figure 27: 200 Amp Meter Socket, Network (120/208), Underground Service

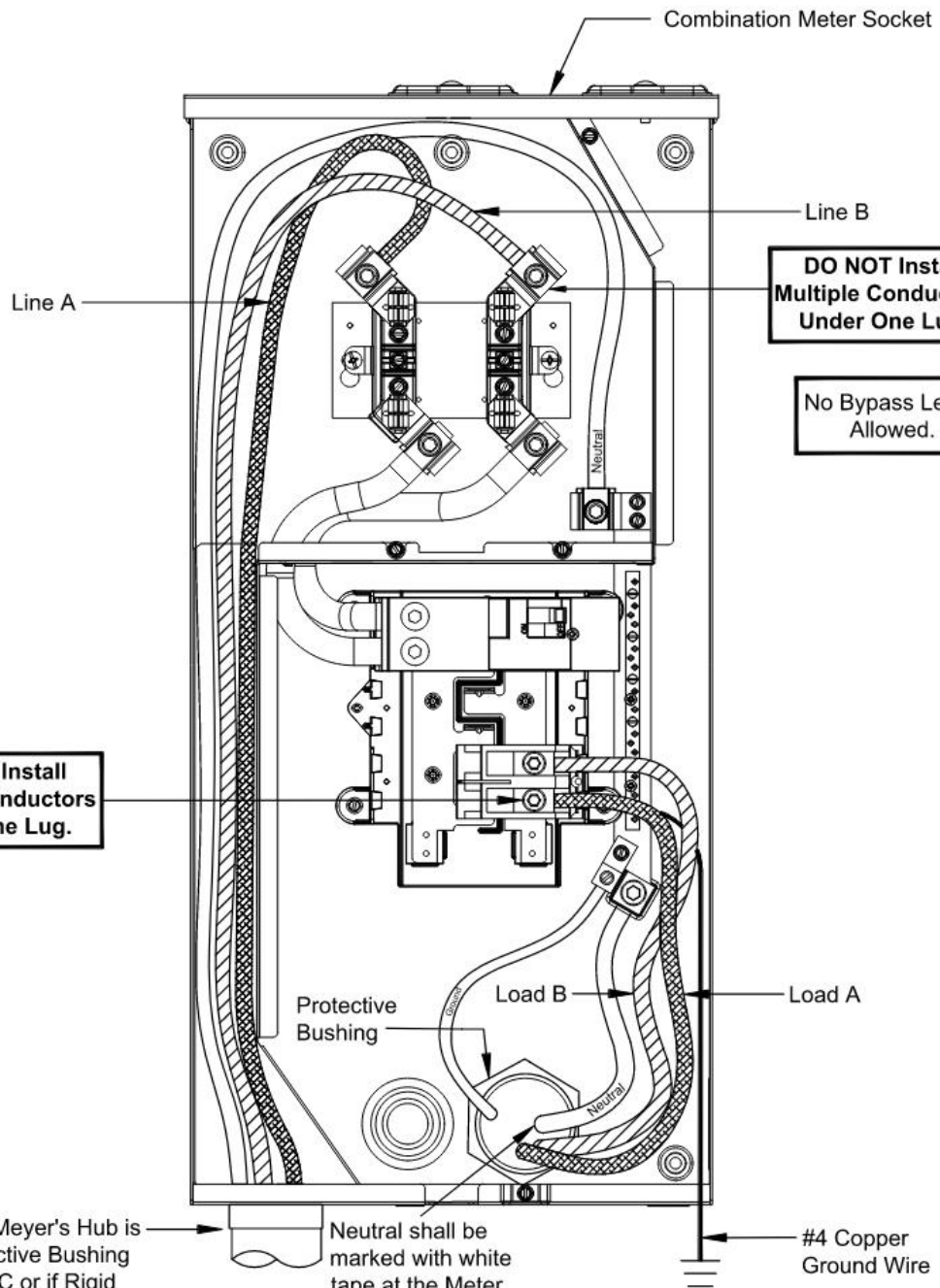

DO NOT Install Multiple Conductors Under One Lug.

DO NOT Install Multiple Conductors Under One Lug.

No Bypass Lever Allowed.

If a Hub Plate or Meyer's Hub is not used, a Protective Bushing is required for PVC or if Rigid Steel is used, a Grounding Bushing is required.

Neutral shall be marked with white tape at the Meter Socket.

Note:

No center installation of conduit allowed. Conduit furnished and installed by Customer in the left or right bottom knockout provided.

All Equipment Furnished and Installed By Customer Unless Otherwise Noted.

02/04/21	DER
01/23/20	SMS
07/15/19	KMH
04/01/09	SDS
REVISIONS	



200 Amp Combination Meter Socket, Underground Service	
DRAWN: SDS	DWG. NO. G18A2047
SCALE: NTS	FIGURE 28
DATE: 11/10/06	

Figure 28: 200 Amp Combination Meter Socket, Underground Service

Note:

This application for 120/208v, 3 wire service.

The Customer will provide and install the 5th lug on **Approved Meter Sockets**. For a list of these, refer to **Appendix A**.

This wire must have white insulation and will be connected as shown. This wire will be provided and installed by the Customer on **Approved Meter Sockets**.

DO NOT Install Multiple Conductors Under One Lug.

If a Hub Plate or Meyer's Hub is not used, a Protective Bushing is required for PVC or if Rigid Steel is used, a Grounding Bushing is required.

Neutral shall be marked with white tape at the Meter Socket.

Note:

No center installation of conduit allowed. Conduit furnished and installed **by Customer** in the left or right bottom knockout provided.

All Equipment Furnished and Installed By Customer Unless Otherwise Noted.

02/04/21	DER
06/11/20	SMS
01/23/20	SMS
06/25/19	KMH
04/01/09	SDS
REVISIONS	



200 Amp Combination Meter Socket, Network (120/208), Underground Service	
DRAWN: LU	DWG. NO. G18A2048
SCALE: NTS	FIGURE 29
DATE: 11/10/16	

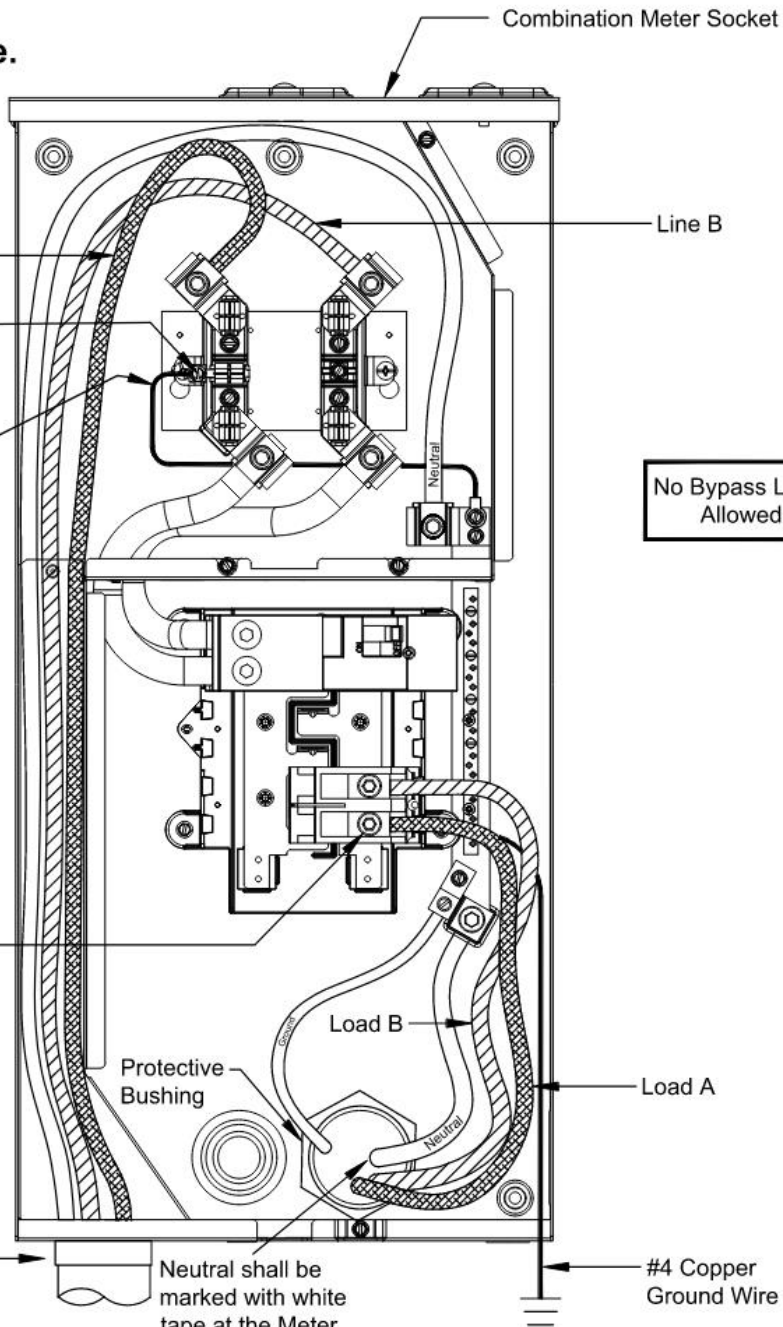
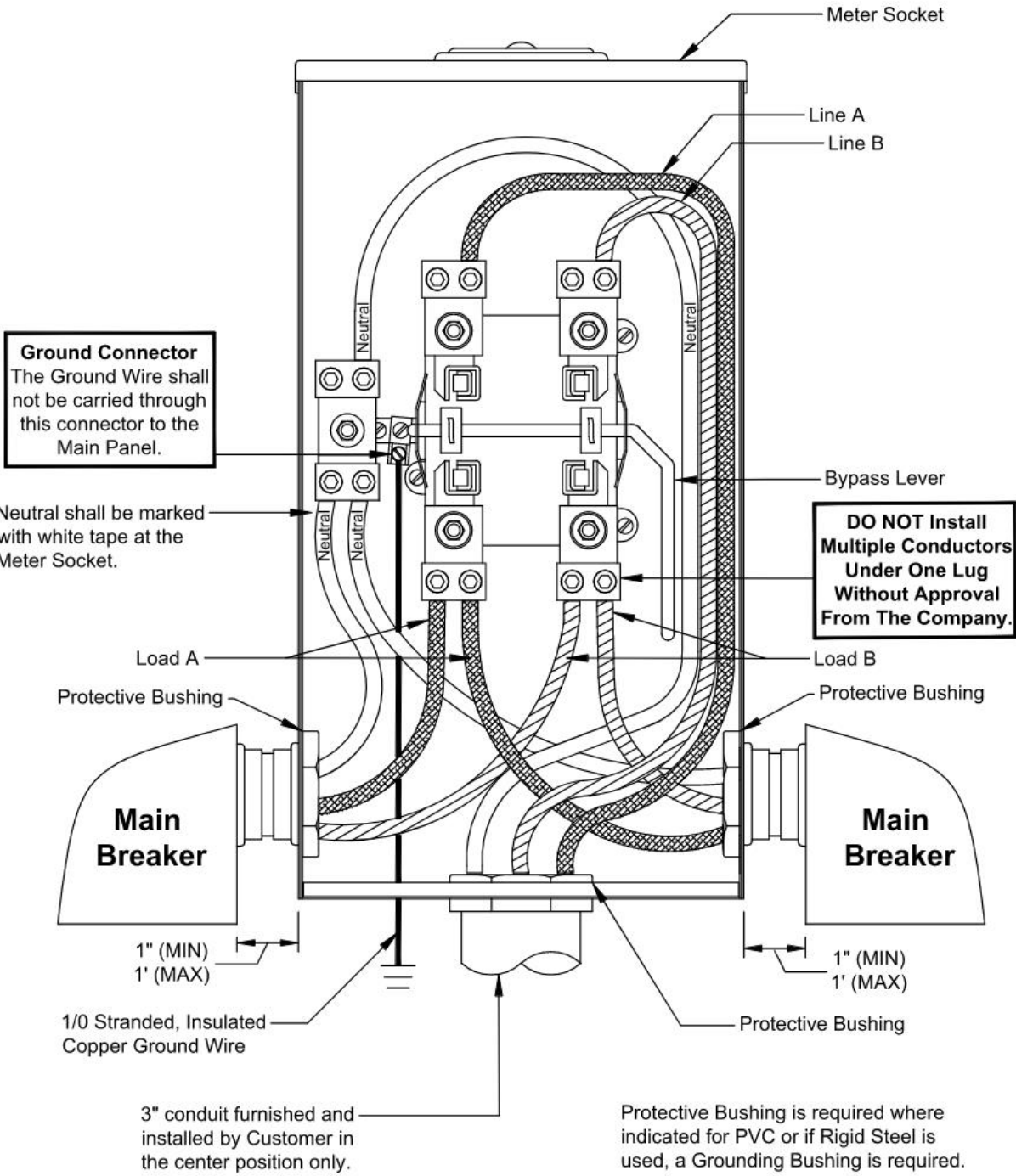

Figure 29: 200 Amp Combination Meter Socket, Network (120/208), Underground Service



All Equipment Furnished & Installed By Customer Unless Otherwise Noted.

02/04/21	DER
07/17/19	KMH
01/22/09	SDS
07/17/06	SDS
05/17/05	SDS
01/01/97	AMA
REVISIONS	



320 Amp Meter Socket, Underground Service	
DRAWN: LU	DWG. NO. G18A2049
SCALE: NTS	FIGURE 30
DATE: 07/01/19	

Figure 30: 320 Amp Meter Socket, Underground Service

Note:

This application for 120/208v, 3 wire service.

This wire must have white insulation and will be connected as shown. This wire will be provided and installed by the Customer on **Approved Meter Sockets**.

The Customer will provide and install the 5th lug on **Approved Meter Sockets**. For a list of these, refer to **Appendix A**.

Ground Connector

The Ground Wire shall not be carried through this connector to the Main Panel.

Neutral shall be marked with white tape at the Meter Socket.

DO NOT install Multiple Conductors Under One Lug Without Approval From The Company.

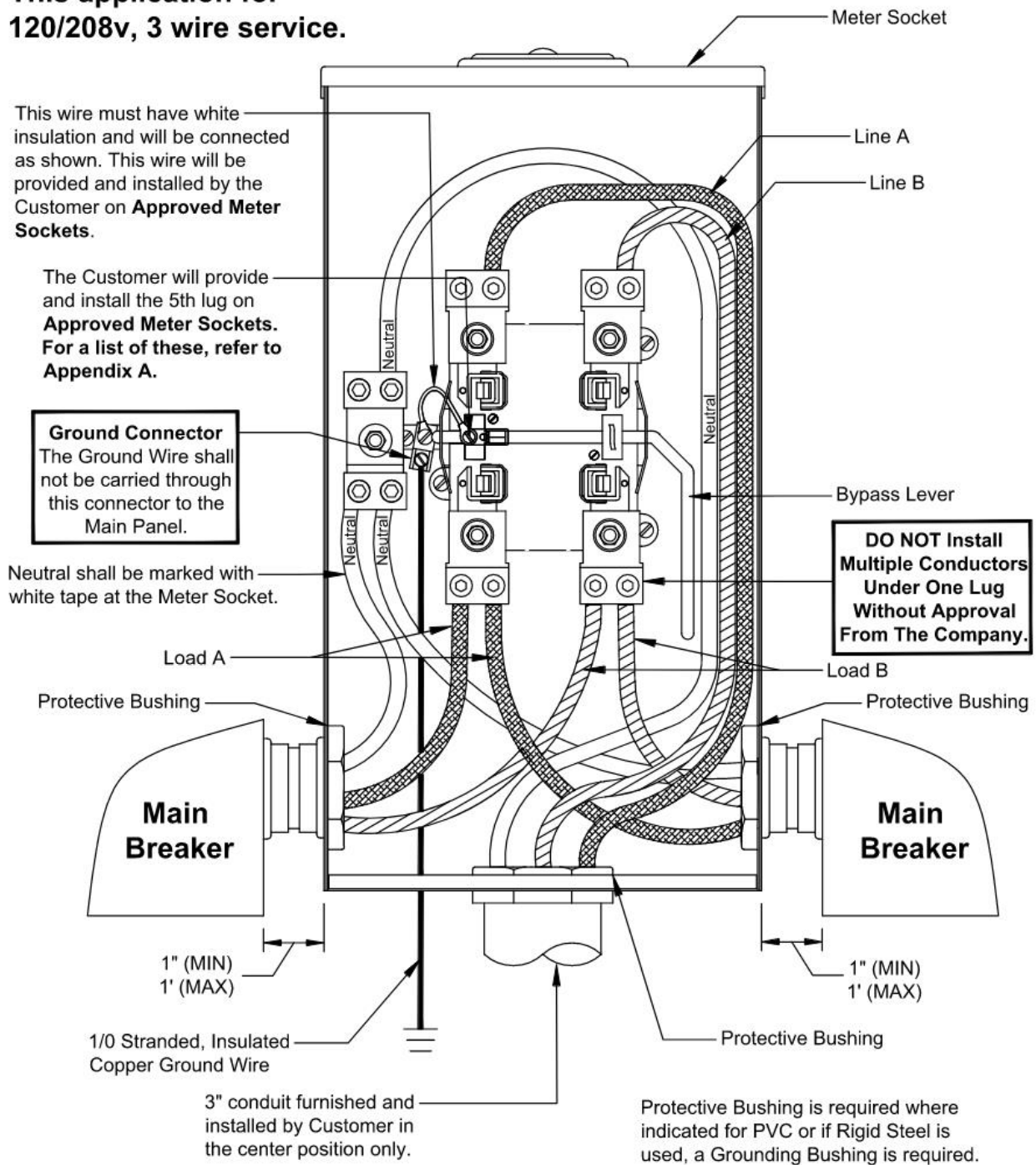

All Equipment Furnished & Installed By Customer Unless Otherwise Noted.

02/04/21 DER
06/11/20 SMS
REVISIONS



320 Amp Meter Socket, Network (120/208), Underground Service

DRAWN: KMH	DWG. NO. G18A2049A
SCALE: NTS	FIGURE 30A
DATE: 07/17/19	

Figure 30A: 320 Amp Meter Socket, Network (120/208), Underground Service

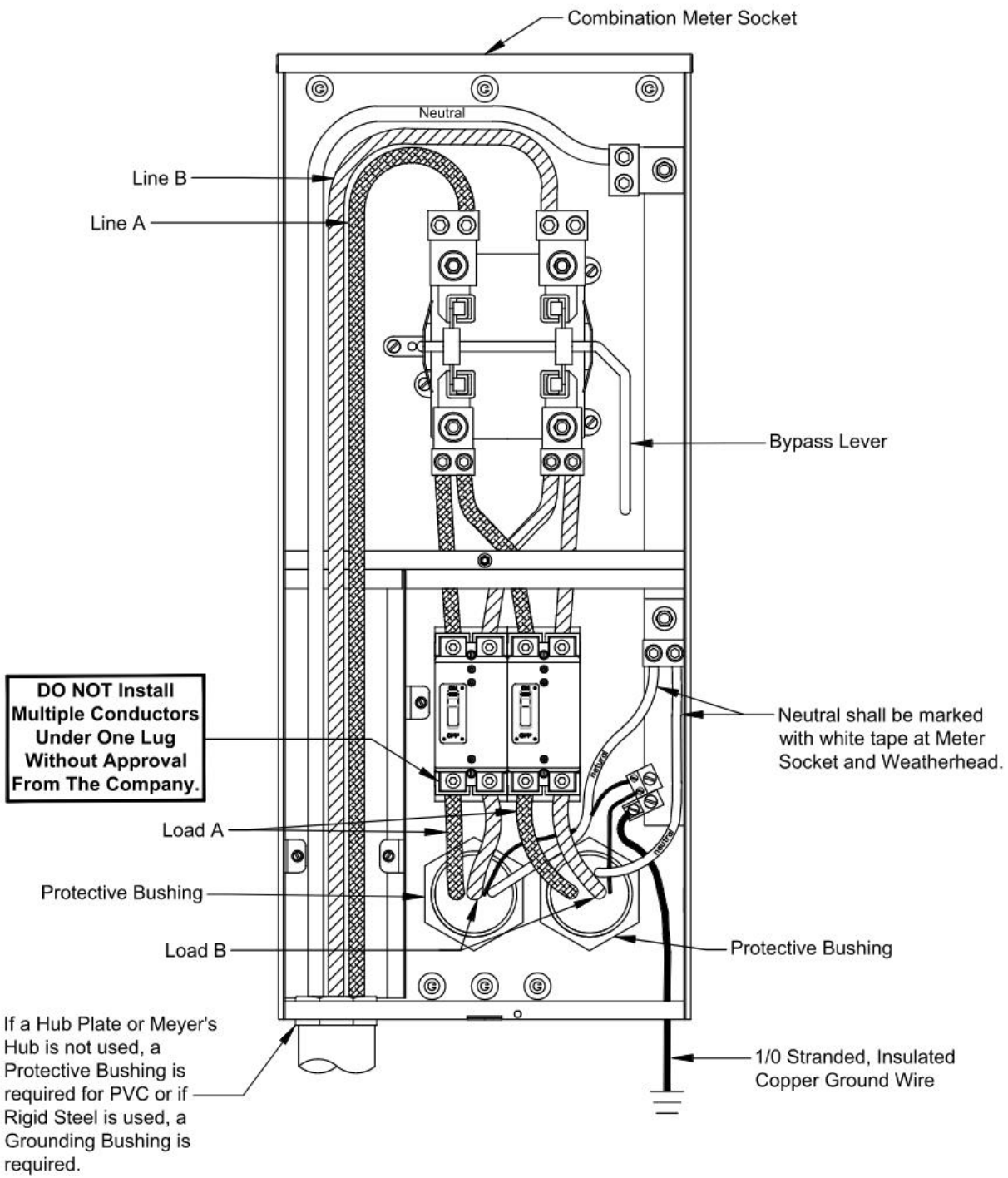

**All Equipment Furnished & Installed
By Customer Unless Otherwise
Noted.**

02/04/21 DER
08/14/19 KMH
REVISIONS



320 Amp Combination Meter Socket, Underground Service	
DRAWN: SDS	DWG. NO. G18A2050
SCALE: NTS	FIGURE 31
DATE: 07/01/19	

Figure 31: 320 Amp Combination Meter Socket, Underground Service

Note:
This application for
120/208v, 3 wire service.

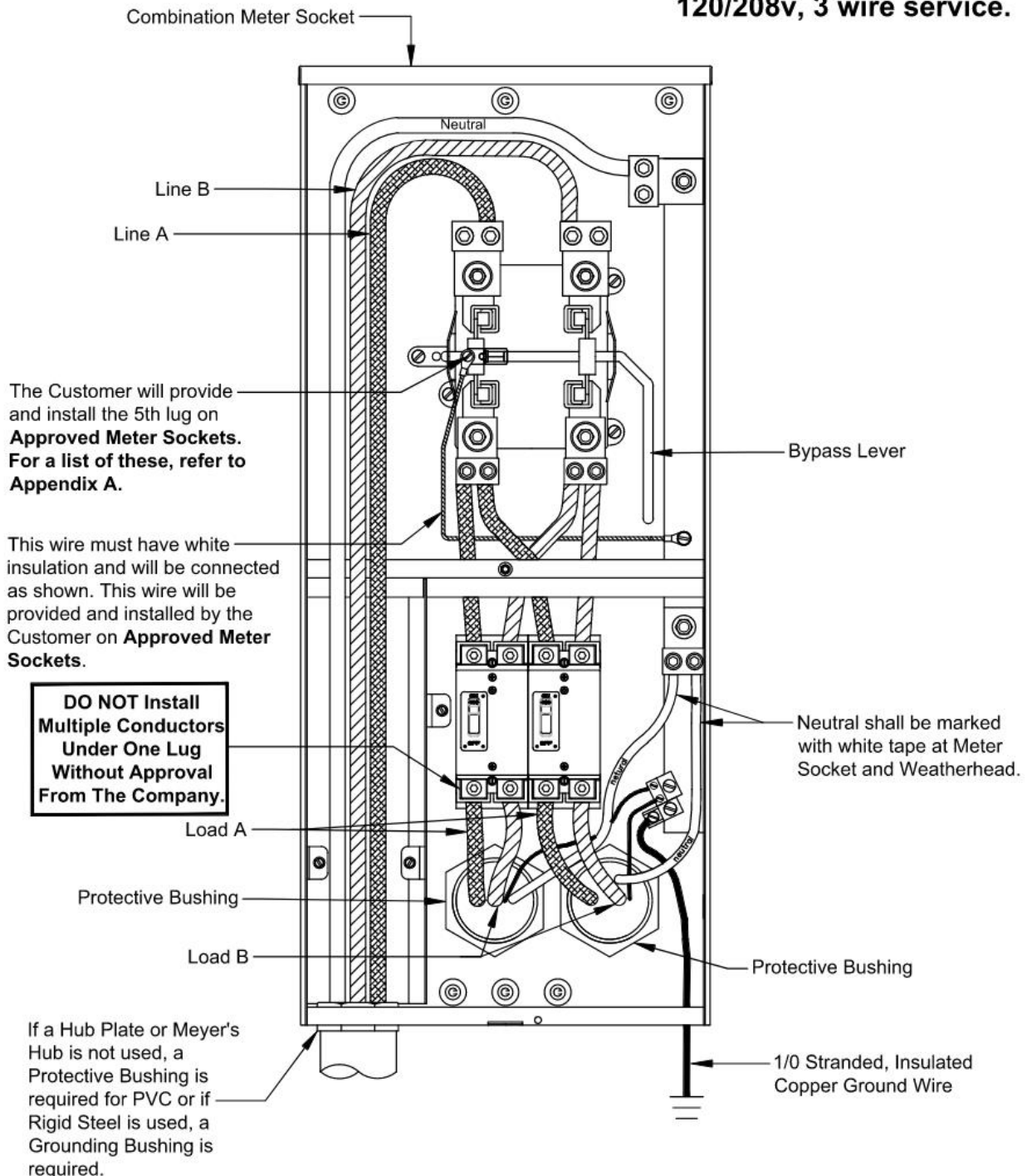

**All Equipment Furnished & Installed
 By Customer Unless Otherwise Noted.**

02/04/21 DER 06/11/20 SMS REVISIONS	 Liberty	320 Amp Combination Meter Socket, Network (120/208), Underground Service	
		DRAWN: KMH	DWG. NO. G18A2050A
		SCALE: NTS	FIGURE 31A
		DATE: 07/26/19	

Figure 31A: 320 Amp Combination Meter Socket, Network (120/208), Underground Service

Caution!
Contact all utilities
before digging

Meter Pedestal leased for a fee.
 The company will own, install, and maintain the pedestal.

Service in Conduit

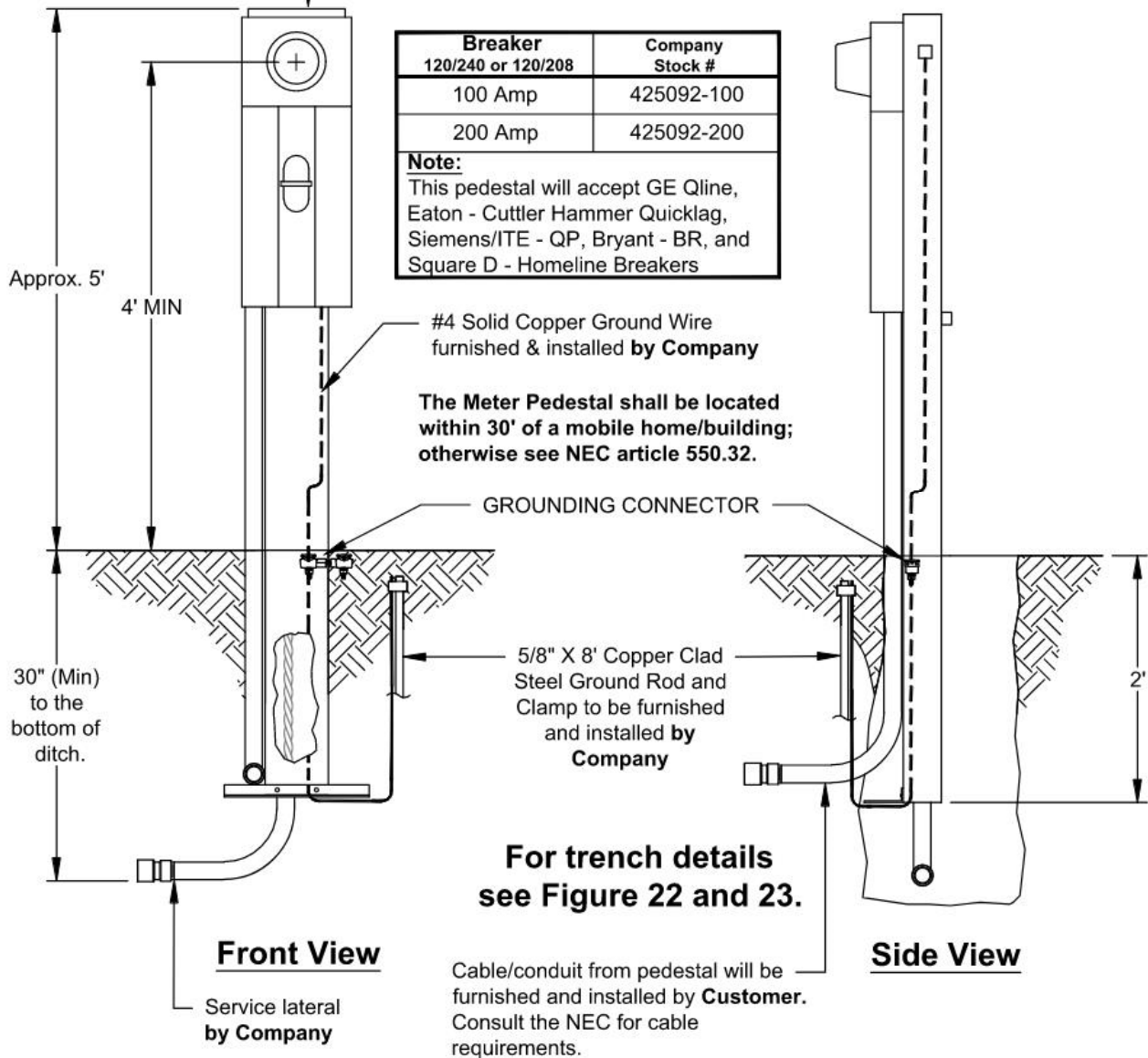

Mobile home parks can only be served 120/240 1Ø as per NEC 550.30.

02/04/21	DER
07/15/19	KMH
07/15/06	SDS
05/17/05	SDS
01/01/97	AMA
REVISIONS	



Meter Pedestal	
DRAWN: LU	DWG. NO. G18A2051
SCALE: NTS	FIGURE 32
DATE: 01/01/95	

Figure 32: Meter Pedestal

7.3 600 AMP TO 800 AMP CT METERING, SINGLE PHASE UNDERGROUND SERVICE

A. General Notes:

1. This arrangement may be utilized for services above 320 amps (continuous) and less than or equal to 800 amps.
2. The service lateral conductors and meter are furnished and installed by the Company. Customer will provide approximate final grade level within six inches (6") prior to service lateral installation.
3. The current transformers (CT) are furnished and installed by the Company.
The Customer shall provide and install the CT/connection cabinet.
 - a. **See Appendix A for list of approved CT/connection cabinets.**
4. The meter socket shall be purchased from the Company and installed by the Customer. The location of this CT Cabinet and Meter will be determined by Liberty.
5. The metering control cable is furnished and installed by the Company.
6. The metering equipment should be "readily accessible" (see definitions). The Company requires a level and unobstructed workspace of 78 inches tall, 18 inches on either side, and 48 inches in front of the metering equipment. Prior approval is required for placement of the metering equipment in alleyways or areas where it may be subjected to damage.

B. Mounting:

1. Meter socket, ground wire, CT/connection cabinet, and conduits for service lateral and metering control cable shall be surface mounted and securely fastened to the structure. The meter socket shall be installed in a level and plumb position. **Flush mounted or recessed metering equipment and service lateral conduit embedded in a wall will not be permitted.**
2. Where the exterior wall is other than brick or concrete blocks, a support frame shall be installed behind the exterior wall to provide a solid mounting surface for the metering equipment.
3. Meter sockets, metering cabinets, and conduit straps shall be installed with the following:
 - a. Lead anchors or double helix concrete screws shall be used with brick or solid concrete surfaces.
 - b. Toggle bolts shall be used with other masonry siding.
 - c. Wood screws shall be used with solid wood surfaces.
 - d. All mounting hardware shall be minimum #12(1/4") corrosion resistant screws.
 - e. A minimum of 4 fasteners shall be used to install any socket or cabinet unless specifically stated otherwise.
4. An intersystem bonding termination bar shall be installed to facilitate the connection of other utility's ground to a common ground. The location of this device shall be located directly below the meter socket or meter combination socket.
 - a. **See Appendix A for list of approved intersystem bonding termination bars.**

5. If PVC is used for the conduit attached to the meter socket, the rigid metal elbow shall be grounded/bonded to the service ground rod unless it is isolated from possible contact by a minimum cover of 18 inches to any part of the elbow as per NEC Article 250.80, Service Raceways and Enclosures.

a. See Appendix A for list of approved grounding clamps.

6. Conduits shall be furnished and installed by Customer.

C. Connections:

All connections inside the CT/connection cabinet shall be made by Company. The Company shall provide the connectors.

D. Conductor Marking:

All neutral conductors shall be clearly marked with colored tape at the point of delivery.

THIS PAGE INTENTIONALLY LEFT BLANK

Caution!
Contact all utilities
before digging

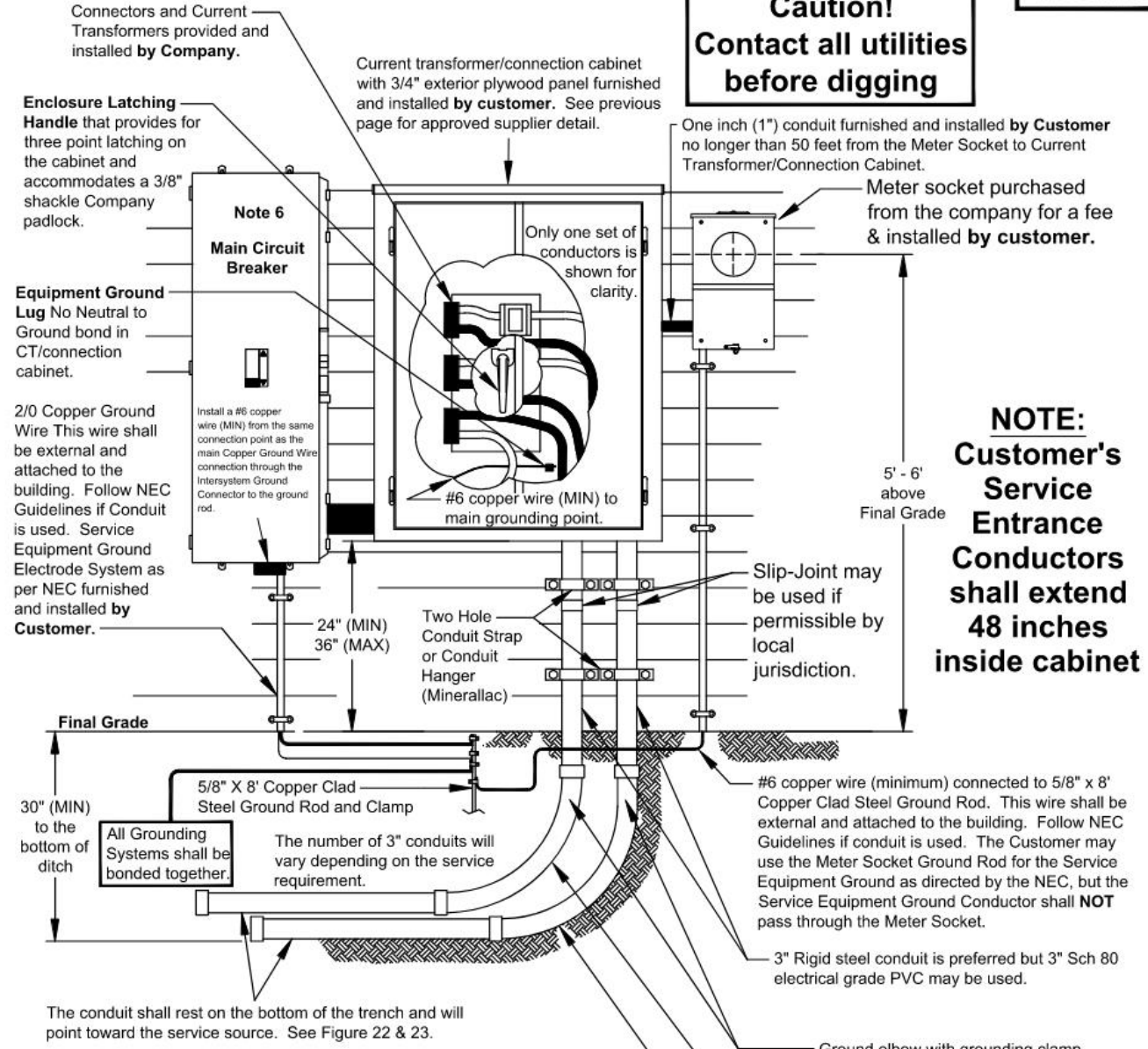

NOTE:
Customer's
Service
Entrance
Conductors
shall extend
48 inches
inside cabinet

NOTES:

1. A 1/4" synthetic pull rope must be installed in the conduit.
2. A conduit vent may be needed depending on the service arrangement and terrain.
3. Line of Sight installation is required. See Definitions.
4. If the service route is longer than 100', contact the company for conduit requirements.
5. A metal elbow that is installed in an underground installation of rigid nonmetallic conduit and is isolated from possible contact by a minimum cover of 18 inches to any part of the elbow shall not be required to be grounded as per NEC Article 250.80, Service Raceways and Enclosures.
6. The Main Disconnecting means can not consist of more than six individual disconnects in combination. These shall all be located external to the building and at one location at the metering point.

!!!! WARNING !!!!
 If this elbow is not supported or if the soil under it is not well compacted, the conduit may pull out of the CT Cabinet resulting in a possible failure of the service.

This denotes undisturbed earth.

**All Equipment Furnished &
 Installed By Customer Unless
 Otherwise Noted.**

02/04/21	DER
06/29/19	KMH
04/01/09	SDS
07/15/06	SDS
05/17/05	SDS
01/01/97	AMA
REVISIONS	



600 Amp to 800 Amp, Current Transformer Metering, Underground Service	
DRAWN: LU	DWG. NO. G18A2052
SCALE: NTS	FIGURE 33
DATE: 01/01/95	

Figure 33: 600 Amp to 800 Amp, Current Transformer Metering, Underground Service

7.4 MULTIPLE METERS, SINGLE PHASE UNDERGROUND SERVICE

A. General Notes:

1. If more than six meters are required, consult the Company for approval of equipment prior to purchase.
2. Service entrance conductors, 5/8" x 8' copper clad steel ground rod, ground rod clamp, ground wire, conduit, conduit straps, lock nuts, bushings, meter socket assembly, hub closing plate, and miscellaneous mounting hardware furnished and installed by the Customer.
3. Meters, service connectors, and service lateral conductors furnished and installed by Company.
4. The meter socket assembly should be "readily accessible" (see definitions). The Company requires a level and unobstructed workspace of 78 inches tall, 18 inches on either side, and 48 inches in front of the meter socket assembly. Prior approval is required for placement of the meter socket assembly in alleyways or areas where it may be subjected to damage.
5. The 100 Amp and 200 Amp meter sockets shall meet the following specifications:
 - a. The latest revision of U.L. 414 and ANSI C12.7 Standards.
 - b. Must be U.L. listed.
 - c. Must have grounding connector for triplex.
 - d. Lug size – 2/0 minimum.
 - e. On 120/208v services, the customer must provide the meter socket with 5th lug installed in the 9 o'clock position.
 - f. **See Appendix A for list of approved meter sockets.**

B. Mounting:

1. Meter socket assembly, ground wire, and conduit shall be surface mounted and securely fastened to the structure. The meter socket assembly shall be installed in a level and plumb position. **Flush mounted metering or recessed equipment and service lateral conduit embedded in a wall will not be permitted.**
2. Where the exterior wall is other than brick or concrete blocks, a support frame shall be installed behind the exterior wall to provide a solid mounting surface for the meter socket.
3. Meter sockets, metering cabinets, and conduit straps shall be installed with the following:
 - a. Lead anchors or double helix concrete screws shall be used with brick or solid concrete surfaces.
 - b. Toggle bolts shall be used with other masonry siding.
 - c. Wood screws shall be used with solid wood surfaces.
 - d. All mounting hardware shall be minimum #12(1/4") corrosion resistant screws.
 - e. A minimum of 4 fasteners shall be used to install any socket or cabinet unless specifically stated otherwise.
4. An intersystem bonding termination bar shall be installed to facilitate the connection of other utility's ground to a common ground. The location of this device shall be located directly below the meter socket or meter combination socket.
 - a. **See Appendix A for list of approved intersystem bonding termination bars.**

5. If PVC is used for the conduit attached to the meter socket, the rigid metal elbow shall be grounded/bonded to the service ground rod unless it is isolated from possible contact by a minimum cover of 18 inches to any part of the elbow as per NEC Article 250.80, Service Raceways and Enclosures.

a. See Appendix A for list of approved grounding clamps.

6. Conduit ends shall be equipped with a proper bushing to protect the conductors.

C. Connections:

1. The Customer is responsible for termination of the incoming wiring if the wire terminates in a main breaker or fuse holder. The Company will terminate the incoming wire if it terminates on bus bar terminals. The main breaker will be removed when the service wire is being pulled by the Company.

2. Do not score load wire when removing insulation.

3. The Customer shall use wire brush or sandpaper to clean all conductors, apply a non-grit type inhibitor and tighten to manufacturer's specifications.

D. Meter Socket Marking:

1. **Before the meters are installed, each socket position and corresponding building unit, i.e. apt number or letter, Suite number or letter, tenant number or letter, or physical address served shall be accurately, clearly, and permanently labeled with an engraved plaque. See the figures for proper location. These shall be screwed, bolted or riveted to the equipment. If the equipment is marked incorrectly, the customer shall be responsible for all costs incurred by Liberty for correcting the meter socket identification. Please note that marker ink or adhesive labels are examples of non-permanent labeling.**

2. **Letters or numbers on the engraved plaque shall be a minimum of one (1) inch in height of contrasting color, i.e., black and white, red and green, orange and blue, etc.**

E. Conductor Marking:

All neutral conductors shall be clearly marked with white tape at the meter socket assembly.

Caution!
Contact all utilities
before digging

The maximum amperage Meter Socket allowed in this configuration is 200A.

- * Provision for Company seal and Company padlock with 3/8" shackle
- ☒☒☒ Marking as required in Section 7.4.D
- ✓ Unit disconnection means with lock-off provisions must accept Company padlock with 3/8" shackle

These connectors shall accept 1-350 MCM AL

The maximum amperage Meter Socket allowed in this configuration is 200A.

This wire shall be external and attached to the building. Follow NEC Guidelines if Conduit is used.

Gang Metering	Ground Wire
2-100 Amp	#4 Cu
2-200 Amp	#2 Cu

No Bypass Lever Allowed.

Gang Metering	Ground Wire
2-100 Amp	#4 Cu
2-200 Amp	#2 Cu

Minimum Conduit	
Gang Metering	Conduit Size
2-100 Amp	2"
2-200 Amp	3"

Rigid steel conduit is preferred but Sch 80 electrical grade PVC may be used.

Two Hole Conduit Strap or Conduit Clamp (Minerallac)
 Slip-Joint may be used if permissible by local jurisdiction.

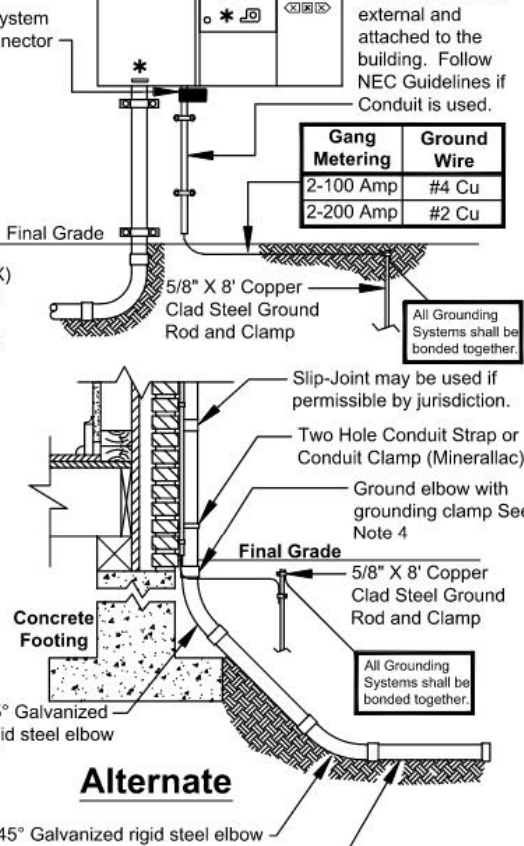
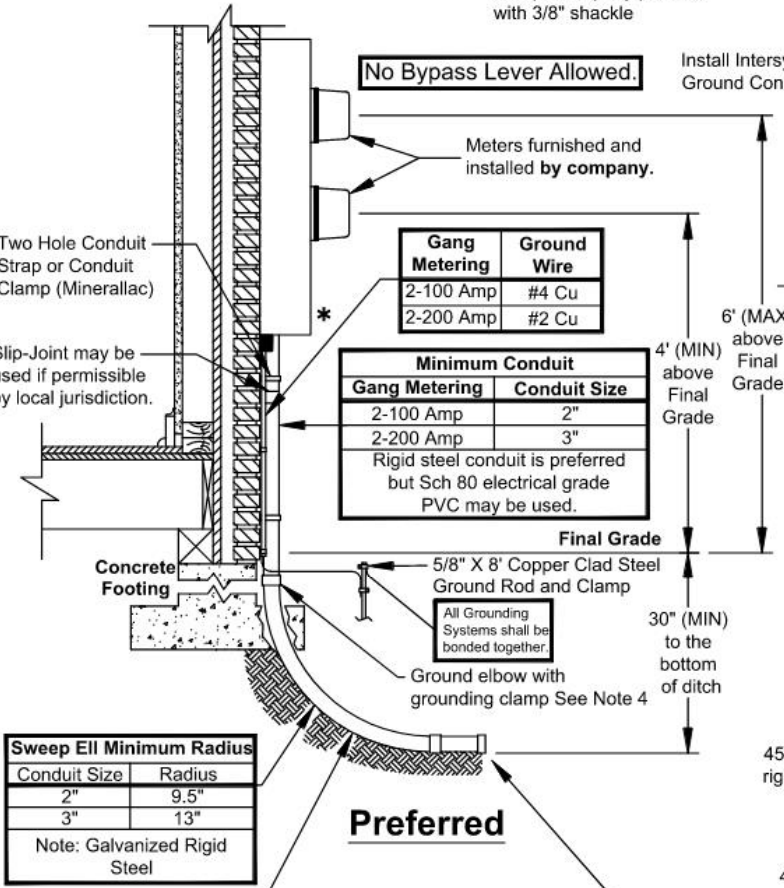

Sweep Ell Minimum Radius	
Conduit Size	Radius
2"	9.5"
3"	13"

Note: Galvanized Rigid Steel

Preferred

Alternate

!!!! WARNING !!!!
 If this elbow is not supported or if the soil under it is not well compacted, the conduit may pull out of the Meter Pack resulting in a possible failure of the service.

This denotes undisturbed earth.

NOTES:

1. A Conduit Vent may be needed depending on the service arrangement and terrain.
2. Line of Sight installation is required. See Definitions.
3. If the service route is longer than 100', contact the Company for conduit requirements.
4. A metal elbow that is installed in an underground installation of rigid nonmetallic conduit and isolated from possible contact by a minimum cover of 18 inches to any part of the elbow shall not be required to be grounded as per NEC Article 250.80, Service Raceways and Enclosures.
5. A 1/4" synthetic pull rope must be installed in the conduit.

**All Equipment Furnished & Installed
 By Customer Unless Otherwise Noted.**

02/04/21	DER
07/17/19	KMH
07/14/09	SDS
07/15/06	SDS
05/17/05	SDS
REVISIONS	



Wiring of two Meters, Underground Service	
DRAWN: LU	DWG. NO. G18A2053
SCALE: NTS	FIGURE 34
DATE: 01/01/95	

Figure 34: Wiring of two Meters, Underground Service

The maximum amperage Meter Socket allowed in this configuration is 200A.

* Provision for company seal and company padlock with 3/8" shackle

☒☒☒ Marking as required in Section 7.4.D

✓ Unit disconnection means with lock-off provisions must accept company padlock with 3/8" shackle

No Bypass Lever Allowed.

Slip-Joint may be used if permissible by local jurisdiction.

Rigid steel conduit is preferred but Sch 80 electrical grade PVC may be used. Number and size of conduits may vary depending on service requirements. Contact the Company for details.

Copper ground wire as per NEC. This wire shall be external and attached to the building. Follow NEC Guidelines if Conduit is used.

Install a #6 copper wire (MIN) from the same connection point as the main Copper Ground Wire connection through the Intersystem Ground Connector to the ground rod.

30" (MIN) to the bottom of ditch

The conduits shall rest on the bottom of the trench and will point toward the service source. See Figure 22 & 23.

All Grounding Systems shall be bonded together.

A minimum of one 5/8" X 8' Copper Clad Steel Ground Rod shall be provided by Customer. However, more than one ground rod may be needed. Consult NEC for requirements.

Galvanized Rigid Steel Ground elbow with grounding clamp See Note 4.

This denotes undisturbed earth.

!!!! WARNING !!!!
If this elbow is not supported or if the soil under it is not well compacted, the conduit may pull out of the Meter Pack resulting in a possible failure of the service.

The number, type, and size of conduits will vary with each installation. Contact the Company for more information.

Caution!
Contact all utilities before digging

NOTES:

1. A Conduit Vent may be needed depending on the service arrangement and terrain.
2. Line of Sight installation is required. See Definitions.
3. If the service route is longer than 100', contact the Company for conduit requirements.
4. A metal elbow that is installed in an underground installation of rigid nonmetallic conduit and isolated from possible contact by a minimum cover of 18 inches to any part of the elbow shall not be required to be grounded as per NEC Article 250.80, Service Raceways and Enclosures.
5. A 1/4" synthetic pull rope must be installed in the conduit.

All Equipment Furnished & Installed By Customer Unless Otherwise Noted.

02/04/21	DER
08/14/19	KMH
02/18/13	SDS
07/15/06	SDS
05/17/05	SDS
01/01/97	AMA
REVISIONS	



Three to Six Meters, Underground Service	
DRAWN: LU	DWG. NO. G18A2054
SCALE: NTS	FIGURE 35
DATE: 01/01/95	

Figure 35: Three to Six Meters, Underground Service

THIS PAGE INTENTIONALLY LEFT BLANK

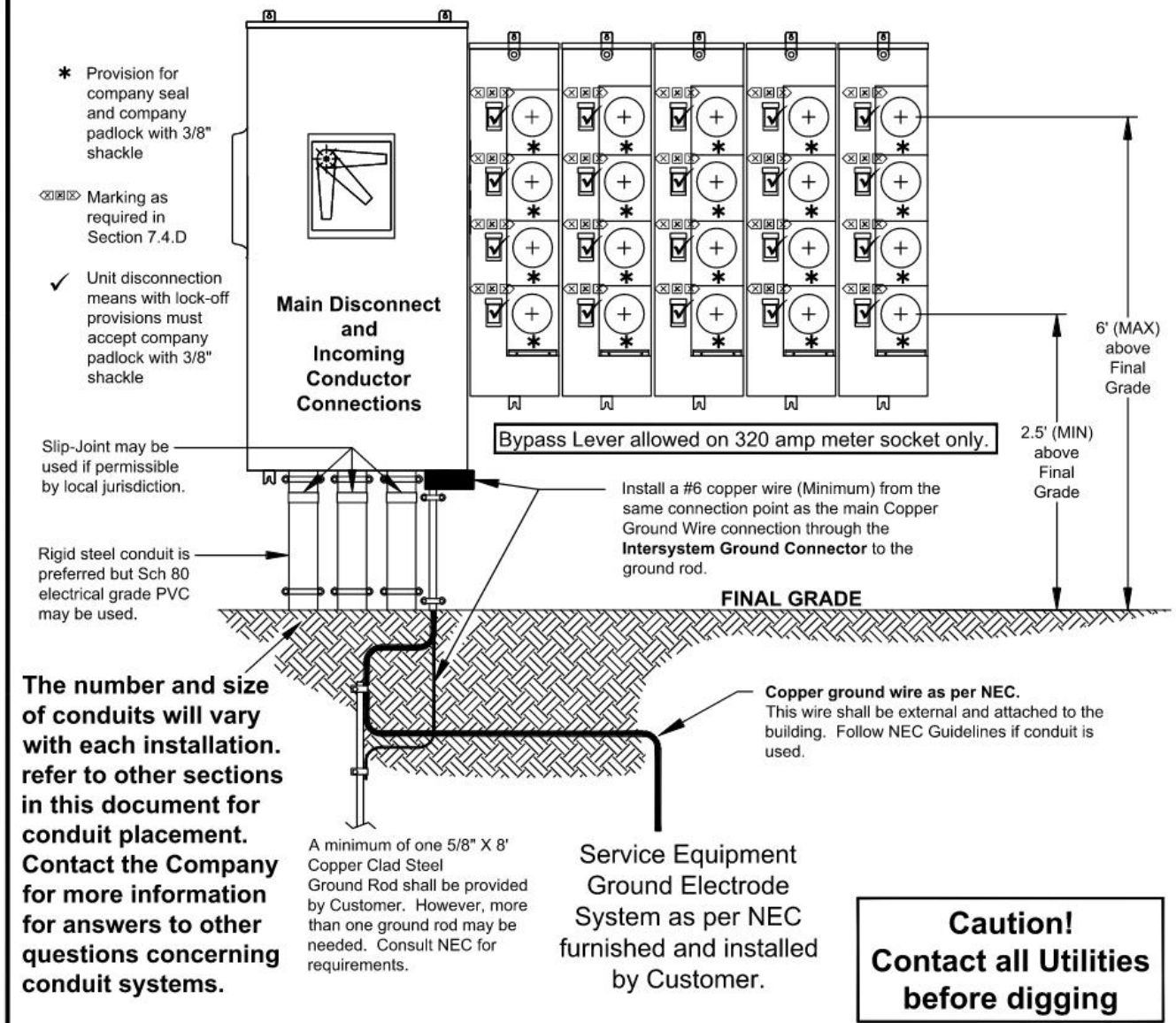

- * Provision for company seal and company padlock with 3/8" shackle
- ☒☒☒ Marking as required in Section 7.4.D
- ✓ Unit disconnection means with lock-off provisions must accept company padlock with 3/8" shackle

Slip-Joint may be used if permissible by local jurisdiction.

Rigid steel conduit is preferred but Sch 80 electrical grade PVC may be used.

The number and size of conduits will vary with each installation. refer to other sections in this document for conduit placement. Contact the Company for more information for answers to other questions concerning conduit systems.

A minimum of one 5/8" X 8' Copper Clad Steel Ground Rod shall be provided by Customer. However, more than one ground rod may be needed. Consult NEC for requirements.

Install a #6 copper wire (Minimum) from the same connection point as the main Copper Ground Wire connection through the Intersystem Ground Connector to the ground rod.

Copper ground wire as per NEC. This wire shall be external and attached to the building. Follow NEC Guidelines if conduit is used.

6' (MAX) above Final Grade

2.5' (MIN) above Final Grade

Notes:

1. A conduit vent may be needed depending on the service arrangement and terrain.
2. Line of Sight installation is required. See Definitions.
3. If the service route is longer than 100', contact the Company for conduit requirements.
4. A metal elbow that is installed in an underground installation of rigid nonmetallic conduit and is isolated from possible contact by a minimum cover of 18 inches to any part of the elbow shall not be required to be grounded as per NEC Article 250.80.
5. A 1/4" synthetic pull rope must be installed in the conduit.
6. If service is supplied from a three phase source, load must be balanced across all phases.

If more than 6 meters are required, please contact the Company for configuration. As a minimum, Liberty will require the riser diagram and cut sheets as proposed by the Electrical Engineer.

All Equipment Furnished & Installed By Customer Unless Otherwise Noted.

02/04/21 DER REVISIONS	 Liberty	Seven or more Meters, Underground Service	
		DRAWN: LU	DWG. NO. G18A2055
		SCALE: NTS	FIGURE 36
		DATE: 08/14/19	

Figure 36: Seven or more Meters, Underground Service

Appendix A

Residential – Approved Equipment Examples

Note: Please get prior approval from Company before purchasing equipment not listed in this Appendix.

Individual Meter Sockets – Overhead

SERVICE SIZE	MILBANK CATALOG #	EATON CATALOG #	TALON/SIEMENS CATALOG #	DURHAM CATALOG #
100A	U7487-RL-TG U7490-RL-TG	UTRS101B UTRS111B UTH101B UTH111B URTRS101B URTRS111B URTH101B URTH111B	UAT111-0G UAT121-0G	UT-RS101B UT-RS111B URT-RS101B URT-RS111B
200A	U7017-RL-TG U7021-RL-TG U7040-RL-TG	UTRS202B UTRS212B UTRS203B UTRS213B UTH202B UTH212B UTH203B UTH213B URTRS202B URTRS212B URTRS203B URTRS213B URTH202B URTH212B URTH203B URTH213B	UAT317-0G UAT327-0G UAT417-0G UAT427-0G	UT-RS202B UT-RS213B URT-RS202B URT-RS213B
320A	U4702-X & (2)K1350	UTH4330UCH ARP00429CH ARP00427CH	47704-01+(2)H56732	UT-H4309T

Individual Meter Sockets – Overhead (5th Lug)

SERVICE SIZE	MILBANK CATALOG #	EATON CATALOG #	TALON/SIEMENS CATALOG #	DURHAM CATALOG #
100A	U7487-RL-TG-5T9 U7490-RL-TG-5T9	UGTRS101B UGTRS111B UGTH101B UGTH111B UGRTRS101B UGRTRS111B UGRTH101B UGRTH111B	UAT111-0BG UAT121-0BG	UGT-RS101B UGT-RS111B UGRT-RS101B UGRT-RS111B
200A	U7017-RL-TG-5T9 U7021-RL-TG-5T9 U7040-RL-TG-5T9	UGTRS202B UGTRS212B UGTRS203B UGTRS213B UGTH202B UGTH212B UGTH203B UGTH213B UGRTRS202B UGRTRS212B UGRTRS203B UGRTRS213B UGRTH202B UGRTH212B UGRTH203B UGRTH213B	UAT317-0BG UAT327-0BG UAT417-0BG UAT427-0BG	UGT-RS202B UGT-RS213B UGRT-RS202B UGRT-RS213B
320A	U4505-X & (2)K1350	UTH4330UCH ARP00429CH ARP00427CH ARP00862CH	47705-02+(2)H56732	UGT-H4309T

Combination Meter Sockets – Overhead

SERVICE SIZE	MILBANK CATALOG #	EATON CATALOG #	TALON/SIEMENS CATALOG #	DURHAM CATALOG #
100A	U5168-XTL-100 U5169-XTL-100	MB816B200BTS* MBT48B200BTS*	MC0816B1200CT*	1009663-EDE*
200A	U5168-XTL-200 U5169-XTL-200	MB816B200BTS MBT48B200BTS	MC0816B1200CT	1009663-EDE
320A	U5059-X-2/200 & K1350	N/A	LG0816B1400RLT+H56732-2 MC0816B1400RLTM+H56732-2 MM0404L1400RLM+(2)QN2200RH	UHC344N5T

* To provide 100A service, this socket will be installed and a separate Customer supplied 100A breaker will be installed to supply the 100A service.

Combination Meter Sockets – Overhead (5th Lug)

SERVICE SIZE	MILBANK CATALOG #	EATON CATALOG #	TALON/SIEMENS CATALOG #	DURHAM CATALOG #
100A	U5168-XTL-100 & 5T8K2 U5169-XTL-100 & 5T8K2	MB816B200STD*	MC0816B1200CT+EC5J2*	1009663A-EDE*
200A	U5168-XTL-200 & K5T U5169-XTL-200 & K5T	MB816B200STD	MC0816B1200CT+EC5J2	1009663A-EDE
320A	U5059-X-2/200 & K1350 & K3865	N/A	LG0816B1400RLT+H35815-2+H56732-2 MC0816B1400RLTM+H35815-2+H56732-2 MM0404L1400RLM+H35815-2+(2)QN2200RH	UHC344N5T-5J

* To provide 100A service, this socket will be installed and a separate Customer supplied 100A breaker will be installed to supply the 100A service.

Duplex Meter Sockets – Overhead

SERVICE SIZE	MILBANK CATALOG #	EATON CATALOG #	TALON/SIEMENS CATALOG #	DURHAM CATALOG #
2-100A	U2852-X-HSP & (2)K1539*	1MP2122R+DS_H2*	WTG2211* WP2211*	SBG1012B*
2-200A	U2862-X-HSP & (2)K1539**	1MP2204R+DS_MH+(6)1MPLK1**	WTG4212**	SBG2022T

* To provide 100A service, these sockets will be installed with Customer supplied 100A breakers.

** To provide 200A service, these sockets will be installed with Customer supplied 200A breakers.

Duplex Meter Sockets – Overhead (5th Lug)

SERVICE SIZE	MILBANK CATALOG #	EATON CATALOG #	TALON/SIEMENS CATALOG #	DURHAM CATALOG #
2-100A	U2852-X-HSP & (2)K1539 & (2)K2381*	1MP2122R+DS_H2+(2)1MM5JK*	WTG2211RJ* WP2211RJ*	SBG1012B5J*
2-200A	U2862-X-HSP & (2)K1539 & (2)K2381**	1MP2204R+DS_MH+(2)1MM5JK+(6)1MPLK1**	WTG4212RJ**	SBG2022T5J

* To provide 100A service, these sockets will be installed with Customer supplied 100A breakers.

** To provide 200A service, these sockets will be installed with Customer supplied 200A breakers.

Meter Stacks (3 To 6) – Overhead

SERVICE SIZE	MILBANK CATALOG #	EATON CATALOG #	TALON/SIEMENS CATALOG #	DURHAM CATALOG #
3-100A	U2853-X-HSP & (3)K1539*	1MP3124R+DS_MH+(9)1MPLK1*	WTG3311*	SBG1013T*
4-100A	U2854-X-HSP & (4)K1539*	1MP4124R+DS_MH+(12)1MPLK1*	WTG4411* WTG5411*	SBG1014T*
5-100A	U2855-X-HSP & (5)K1539*	1MP5126R+DS_MH+(15)1MPLK1*	WTG4511* WTG6511*	SBG1015T*
6-100A	U2856-X-HSP & (6)K1539*	1MP6126R+DS_MH+(18)1MPLK1*	WTG6611*	SBG1016T*
3-200A	U2863-X-HSP & (3)K1539**	1MP3206R+DS_MH+(9)1MPLK1**	WTG4312**	SBG2023T
4-200A	U2864-X-HSP & (4)K1539**	1MP4206R+DS_MH+(12)1MPLK1**	WTG6412**	SBG2024T
5-200A	U2865-X-HSP & (5)K1539**	1MP5206R+DS_MH+(15)1MPLK1**	WTG6512**	SBG2025T
6-200A	U2866-X-HSP & (6)K1539**	1MP6206R+DS_MH+(18)1MPLK1**	WTG8612**	SBG2026T

* To provide 100A service, these sockets will be installed with Customer supplied 100A breakers.

** To provide 200A service, these sockets will be installed with Customer supplied 200A breakers.

Meter Stacks (3 To 6) – Overhead (5th Lug)

SERVICE SIZE	MILBANK CATALOG #	EATON CATALOG #	TALON/SIEMENS CATALOG #	DURHAM CATALOG #
3-100A	U2853-X-HSP & (3)K1539 & (3)K2381*	1MP3124R+DS_MH+(3)1MM5JK+(9)1MPLK1*	WTG3311RJ*	SBG1013T5J*
4-100A	U2854-X-HSP & (4)K1539 & (4)K2381*	1MP4124R+DS_MH+(4)1MM5JK+(12)1MPLK1*	WTG4411RJ*	SBG1014T5J*
5-100A	U2855-X-HSP & (5)K1539 & (5)K2381*	1MP5126R+DS_MH+(5)1MM5JK+(15)1MPLK1*	WTG4511RJ* WTG6511RJ*	SBG1015T5J*
6-100A	U2856-X-HSP & (6)K1539 & (6)K2381*	1MP6126R+DS_MH+(6)1MM5JK+(18)1MPLK1*	WTG4611RJ* WTG6611RJ*	SBG1016T5J*
3-200A	U2863-X-HSP & (3)K1539 & (3)K2381**	1MP3206R+DS_MH+(3)1MM5JK+(9)1MPLK1**	WTG4312RJ**	SBG2023T5J
4-200A	U2864-X-HSP & (4)K1539 & (4)K2381**	1MP4206R+DS_MH+(4)1MM5JK+(12)1MPLK1**	WTG4412RJ** WTG6412RJ**	SBG2024T5J
5-200A	U2865-X-HSP & (5)K1539 & (5)K2381**	1MP5206R+DS_MH+(5)1MM5JK+(15)1MPLK1**	WTG6512RJ**	SBG2025T5J
6-200A	U2866-X-HSP & (6)K1539 & (6)K2381**	1MP6206R+DS_MH+(6)1MM5JK+(18)1MPLK1**	WTG8612RJ**	SBG2026T5J

* To provide 100A service, these sockets will be installed with Customer supplied 100A breakers.

** To provide 200A service, these sockets will be installed with Customer supplied 200A breakers.

Individual Meter Sockets – Underground

SERVICE SIZE	MILBANK CATALOG #	EATON CATALOG #	TALON/SIEMENS CATALOG #	DURHAM CATALOG #
200A	U7018-O-TG U7018-XL-TG UL7040-O-TG UL7040-XL-TG U7043-XL-TG	UTRS212A	UAT417-XG UAT417-PG UAT427-XG UAT427-PG	UT-RS213A UT-RS213C URT-RS213A URT-RS213C
		UTRS213A		
		UTRS212C		
		UTRS213C		
		UTH212A		
		UTH213A		
		UTH212C		
		UTH213C		
		URTRS212A		
		URTRS213A		
		URTRS212C		
		URTRS213C		
		URTH212A		
		URTH213A		
URTH212C				
URTH213C				
320A	U4702-X & (2)K1350	UTH4330UCH ARP00429CH ARP00427CH	47704-01+H56933+(2)H56732	UT-H4309U

Individual Meter Sockets – Underground (5th Lug)

SERVICE SIZE	MILBANK CATALOG #	EATON CATALOG #	TALON/SIEMENS CATALOG #	DURHAM CATALOG #
200A	U7018-O-TG-5T9 U7018-XL-TG-5T9 UL7040-O-TG-5T9 UL7040-XL-TG-5T9 U7043-XL-TG-5T9	UGTRS212A UGTRS213A UGTRS212C UGTRS213C UGTH212A UGTH213A UGTH212C UGTH213C UGRTRS212A UGRTRS213A UGRTRS212C UGRTRS213C UGRTH212A UGRTH213A UGRTH212C UGRTH213C	UAT417-XBG UAT417-PBG UAT427-XBG UAT427-PBG	UGT-RS213A UGT-RS213C UGRT-RS213A UGRT-RS213C
320A	U4505-X & (2)K1350	UTH4330UCH ARP00429CH ARP00427CH ARP00862CH	47705-82KCPL	UGT-H4309U

Combination Meter Sockets – Underground

SERVICE SIZE	MILBANK CATALOG #	EATON CATALOG #	TALON/SIEMENS CATALOG #	DURHAM CATALOG #
200A	U5168-XTL-200 U5169-XTL-200	MB816200BTS MBT48B200BTS	MC0816B1200CT	1009663-EDE
320A	U5059-X-2/200 & K1350	N/A	LG0816B1400RLT MC0816B1400RLTM MM0404L1400RLM+(2)QN2200RH	UHC344N5U

Combination Meter Sockets – Underground (5th Lug)

SERVICE SIZE	MILBANK CATALOG #	EATON CATALOG #	TALON/SIEMENS CATALOG #	DURHAM CATALOG #
200A	U5168-XTL-200 & K5T U5169-XTL-200 & K5T	MB816B200STD	MC0816B1200CT+EC5J2	1009663A-EDE
320A	U5059-X-2/200 & K1350 & K3865	N/A	LG0816B1400RLT+H35815-2 MC0816B1400RLTM+H35815-2 MM0404L1400RLM+H35815-2+(2)QN2200RH	UHC344N5U-5J

Duplex Meter Sockets – Underground

SERVICE SIZE	MILBANK CATALOG #	EATON CATALOG #	TALON/SIEMENS CATALOG #	DURHAM CATALOG #
2-100A	U2852-X-HSP & (2)K1539*	1MP2122R*	WTG2211* WP2211*	SBG1012C*
2-200A	U2862-X-HSP & (2)K1539**	1MP2204R+(6)1MPLK1**	WTG4212**	SBG2022U

* To provide 100A service, these sockets will be installed with Customer supplied 100A breakers.

** To provide 200A service, these sockets will be installed with Customer supplied 200A breakers.

Duplex Meter Sockets – Underground (5th Lug)

SERVICE SIZE	MILBANK CATALOG #	EATON CATALOG #	TALON/SIEMENS CATALOG #	DURHAM CATALOG #
2-100A	U2852-X-HSP & (2)K1539 & (2)K2381*	1MP2122R+(2)1MM5JK*	WTG2211RJ* WP2211RJ*	SBG1012C5J*
2-200A	U2862-X-HSP & (2)K1539 & (2)K2381**	1MP2204R+(2)1MM5JK+(6)1MPLK1**	WTG4212RJ**	SBG2022U5J

* To provide 100A service, these sockets will be installed with Customer supplied 100A breakers.

** To provide 200A service, these sockets will be installed with Customer supplied 200A breakers.

Meter Stacks (3 To 6) – Underground

SERVICE SIZE	MILBANK CATALOG #	EATON CATALOG #	TALON/SIEMENS CATALOG #	DURHAM CATALOG #
3-100A	U2853-X-HSP & (3)K1539*	1MP3124R+(9)1MPLK1*	WTG3311*	SBG1013U*
4-100A	U2854-X-HSP & (4)K1539*	1MP4124R+(12)1MPLK1*	WTG4411* WTG5411*	SBG1014U*
5-100A	U2855-X-HSP & (5)K1539*	1MP5126R+(15)1MPLK1*	WTG4511* WTG6511*	SBG1015U*
6-100A	U2856-X-HSP & (6)K1539*	1MP6126R+(18)1MPLK1*	WTG6611*	SBG1016U*
3-200A	U2863-X-HSP & (3)K1539**	1MP3206R+(9)1MPLK1**	WTG4312**	SBG2023U
4-200A	U2864-X-HSP & (4)K1539**	1MP4206R+(12)1MPLK1**	WTG6412**	SBG2024U
5-200A	U2865-X-HSP & (5)K1539**	1MP5206R+(15)1MPLK1**	WTG6512**	SBG2025U
6-200A	U2866-X-HSP & (6)K1539**	1MP6206R+(18)1MPLK1**	WTG8612**	SBG2026U

* To provide 100A service, these sockets will be installed with Customer supplied 100A breakers.

** To provide 200A service, these sockets will be installed with Customer supplied 200A breakers.

Meter Stacks (3 To 6) – Underground (5th Lug)

SERVICE SIZE	MILBANK CATALOG #	EATON CATALOG #	TALON/SIEMENS CATALOG #	DURHAM CATALOG #
3-100A	U2853-X-HSP & (3)K1539 & (3)K2381*	1MP3124R+(3)1MM5JK+(9)1MPLK1*	WTG3311RJ*	SBG1013U5J*
4-100A	U2854-X-HSP & (4)K1539 & (4)K2381*	1MP4124R+(4)1MM5JK+(12)1MPLK1*	WTG4411RJ*	SBG1014U5J*
5-100A	U2855-X-HSP & (5)K1539 & (5)K2381*	1MP5126R+(5)1MM5JK+(15)1MPLK1*	WTG4511RJ* WTG6511RJ*	SBG1015U5J*
6-100A	U2856-X-HSP & (6)K1539 & (6)K2381*	1MP6126R+(6)1MM5JK+(18)1MPLK1*	WTG4611RJ* WTG6611RJ*	SBG1016U5J*
3-200A	U2863-X-HSP & (3)K1539 & (3)K2381**	1MP3206R+(3)1MM5JK+(9)1MPLK1**	WTG4312RJ**	SBG2023U5J
4-200A	U2864-X-HSP & (4)K1539 & (4)K2381**	1MP4206R+(4)1MM5JK+(12)1MPLK1**	WTG4412RJ** WTG6412RJ**	SBG2024U5J
5-200A	U2865-X-HSP & (5)K1539 & (5)K2381**	1MP5206R+(5)1MM5JK+(15)1MPLK1**	WTG6512RJ**	SBG2025U5J
6-200A	U2866-X-HSP & (6)K1539 & (6)K2381**	1MP6206R+(6)1MM5JK+(18)1MPLK1**	WTG8612RJ**	SBG2026U5J

* To provide 100A service, these sockets will be installed with Customer supplied 100A breakers.

** To provide 200A service, these sockets will be installed with Customer supplied 200A breakers.

CT/Connection Cabinet

SERVICE SIZE	MILBANK CATALOG #	TALON/SIEMENS CATALOG #	DURHAM CATALOG #
600A TO 800A	363616-CT3R-WB	LG163636CTS1	363616-DDW

Intersystem Bonding Termination Bar



MANUFACTURER	CATALOG #
ARLINGTON	GBB50 (#6-1/0)

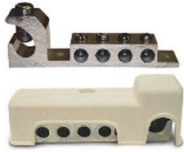

MANUFACTURER	CATALOG #
EATON	MSEGR2 (#8-1/0)

Grounding Clamps



CONDUIT SIZE	TAP CONDUCTOR RANGE	MANUFACTURER	CATALOG #
1/2" – 1"	#10 SOL – #2 STR	PENN-UNION	KP-1
			KP-1-DB
		BURNDY	C-11N
			C-11D
		NSI INDUSTRIES	G-1-S
			G-1
		ERICO	CWP1JSH
			CWP1JU
		HARGER	BGC4
			J
THOMAS & BETTS	JD		
1-1/4" – 2"	#10 SOL – #2 STR	PENN-UNION	KP-2
			KP-2-DB
		BURNDY	C-22
			C-22D
		NSI INDUSTRIES	G-2-S
			G-2
		ERICO	CWP2JSH
			CWP2JU
		HARGER	BGC41.25-2
			J2BB
THOMAS & BETTS	J2D		
2-1/2" – 4"	#10 SOL – #2 STR	PENN-UNION	KP-4
		BURNDY	C-4
		NSI INDUSTRIES	G-4-S
			G-4
			G-4-SBS
		HARGER	BGC42.5-4
4-1/2" – 6"	#10 SOL – #2 STR	PENN-UNION	KP-6
		BURNDY	C-8
		NSI INDUSTRIES	G-6-S
			G-6

Appendix B

These excerpts from the NEC are placed here for your convenience. For more detail information, please consult the NEC.

Part VI. Service Equipment — Disconnecting Means

230.70 General. Means shall be provided to disconnect all ungrounded conductors in a building or other structure from the service conductors.

(A) Location. The service disconnecting means shall be installed in accordance with 230.70(A)(1), (A)(2), and (A)(3).

(1) Readily Accessible Location. The service disconnecting means shall be installed at a readily accessible location either outside of a building* or structure or inside nearest the point of entrance of the service conductors.

(2) Bathrooms. Service disconnecting means shall not be installed in bathrooms.

(3) Remote Control. Where a remote control device(s) is used to actuate the service disconnecting means, the service disconnecting means shall be located in accordance with 230.70(A)(1).

(B) Marking. Each service disconnect shall be permanently marked to identify it as a service disconnect.

(C) Suitable for Use. Each service disconnecting means shall be suitable for the prevailing conditions. Service equipment installed in hazardous (classified) locations shall comply with the requirements of Articles 500 through 517.

* Liberty requires an external disconnect.

230.71 Maximum Number of Disconnects.

Each service shall have only one disconnecting means unless the requirements of 230.71(B) are met.

(A) General. For the purpose of this section, disconnecting means installed as part of listed equipment and used solely for the following shall not be considered a service disconnecting means:

- (1) Power monitoring equipment
- (2) Surge-protective device(s)
- (3) Control circuit of the ground-fault protection system
- (4) Power-operable service disconnecting means

(B) Two to Six Service Disconnecting Means.

Two to six service disconnects shall be permitted for each service permitted by 230.2 or for each set of service-entrance conductors permitted by 230.40, Exception No. 1, 3, 4, or 5. The two to six service disconnecting means shall be permitted to consist of a combination of any of the following:

- (1) Separate enclosures with a main service disconnecting means in each enclosure
- (2) Panelboards with a main service disconnecting means in each panelboard enclosure
- (3) Switchboard(s) where there is only one service disconnect in each separate vertical section where there are barriers separating each vertical section
- (4) Service disconnects in switchgear or metering centers where each disconnect is located in a separate compartment

Table 250.66 Grounding Electrode Conductor for Alternating-Current Systems

Size Of Largest Ungrounded Conductor Or Equivalent Area For Parallel Conductors (AWG/kcmil)		Size Of Grounding Electrode Conductor (AWG/kcmil)	
Copper	Aluminum or Copper-Clad Aluminum	Copper	Aluminum or Copper-Clad Aluminum
2 or smaller	1/0 or smaller	8	6
1 or 1/0	2/0 or 3/0	6	4
2/0 or 3/0	4/0 or 250	4	2
Over 3/0 through 350	Over 250 through 500	2	1/0
Over 350 through 600	Over 500 through 900	1/0	3/0
Over 600 through 1100	Over 900 through 1750	2/0	4/0
Over 1100	Over 1750	3/0	250

Notes:

1. If multiple sets of service-entrance conductors connect directly to a service drop, set of overhead service conductors, set of underground service conductors, or service lateral, the equivalent size of the largest service-entrance conductor shall be determined by the largest sum of the areas of the corresponding conductors of each set.
2. Where there are no service-entrance conductors, the grounding electrode size shall be determined by the equivalent size of the largest service-entrance conductor required for the load to be served.
3. See installation restrictions in 250.64.

Table 310.15(C)(1) Adjustment Factors for More Than Three Current-Carrying Conductors

Number of Conductors*	Percent of Values in Table 310.16 Through Table 310.19 as Adjusted for Ambient Temperature if Necessary
4-6	80
7-9	70
10-20	50
21-30	45
31-40	40
41 and above	35

* Number of conductors is the total number of conductors in the raceway or cable, including spare conductors. The count shall be adjusted in accordance with 310.15 (E) and (F). The count shall not include conductors that are connected to electrical components that cannot be simultaneously energized.

Table 310.16 Ampacities of Insulated Conductors with Not More Than Three Current-Carrying Conductors in Raceway, Cable, or Earth (Directly Buried)

Temperature Rating of Conductor [See Table 310.4(A)]							
Size AWG or kcmil	60°C (140°F)	75°C (167°F)	90°C (194°F)	60°C (140°F)	75°C (167°F)	90°C (194°F)	Size AWG or kcmil
	Types TW, UF	Types RHW, THHW, THW, THWN, XHHW, XHWN, USE, ZW	Types TBS, SA, SIS, FEP, FEPB, MI, PFA, RHH, RHW-2, THHN, THHW, THW-2, THWN-2, USE-2, XHH, XHHW, XHHW-2, XHWN, XHWN-2, XHHN, Z, ZW-2	Types TW, UF	Types RHW, THHW, THW, THWN, XHHW, XHWN, USE	Types TBS, SA, SIS, THHN, THHW, THW-2, THWN-2, RHH, RHW-2, USE-2, XHH, XHHW, XHHW-2, XHWN, XHWN-2, XHHN	
	COPPER			ALUMINUM OR COPPER-CLAD ALUMINUM			
18**	—	—	14	—	—	—	—
16**	—	—	18	—	—	—	—
14**	15	20	25	—	—	—	—
12**	20	25	30	15	20	25	12**
10**	30	35	40	25	30	35	10**
8	40	50	55	35	40	45	8
6	55	65	75	40	50	55	6
4	70	85	95	55	65	75	4
3	85	100	115	65	75	85	3
2	95	115	130	75	90	100	2
1	110	130	145	85	100	115	1
1/0	125	150	170	100	120	135	1/0
2/0	145	175	195	115	135	150	2/0
3/0	165	200	225	130	155	175	3/0
4/0	195	230	260	150	180	205	4/0
250	215	255	290	170	205	230	250
300	240	285	320	195	230	260	300
350	260	310	350	210	250	280	350
400	280	335	380	225	270	305	400
500	320	380	430	260	310	350	500
600	350	420	475	285	340	385	600
700	385	460	520	315	375	425	700
750	400	475	535	320	385	435	750
800	410	490	555	330	395	445	800
900	435	520	585	355	425	480	900
1000	455	545	615	375	445	500	1000
1250	495	590	665	405	485	545	1250
1500	525	625	705	435	520	585	1500
1750	545	650	735	455	545	615	1750
2000	555	665	750	470	560	630	2000

Notes:

1. Section 310.15(B) shall be referenced for ampacity correction factors where the ambient temperature is other than 30°C (86°F).
2. Section 310.15(C)(1) shall be reference for more than three current-carrying conductors.
3. Section 310.16 shall be referenced for conditions of use.

* Section 240.1(D) shall be referenced for conductor overcurrent protection limitations, except as modified elsewhere in the Code.

Most Common Reasons for Delays in Service Connection

- CUSTOMER HAS NOT APPLIED FOR SERVICE
- THE SERVICE PATH WAS NOT CLEAR
- METER SOCKET WAS NOT GROUNDED
- NO GROUND ROD OR IMPROPER GROUND ROD
- METER SOCKET WAS EITHER TOO HIGH OR LOW
- METER SOCKET WAS NOT PROPERLY ATTACHED
- METER SOCKET WAS IMPROPERLY WIRED
- WEATHERHEAD WAS TOO LOW
- NO SERVICE ATTACHMENT POINT OR BRACKET
- SERVICE ATTACHMENT POINT WAS TOO LOW
- WRONG SIZE OR TYPE OF CONDUIT (WATER PIPE IS NOT ALLOWED)
- NO STRAPS ON THE CONDUIT
- TRENCH WAS TOO SHALLOW
- TRENCH PATH WAS NOT LINE OF SIGHT
- WRONG GROUND WIRE SIZE
- GROUND WIRE WAS NOT ATTACHED
- NO PROTECTIVE BUSHINGS ON THE CONDUITS
- CONDUIT WAS NOT PROPERLY SUPPORTED IN THE BOTTOM OF THE TRENCH
- LOCAL INSPECTION NOT OBTAINED (AS REQUIRED)
- MULTIPLE SOCKETS/SERVICES WERE NOT LABELED CORRECTLY
- CONSTRUCTION FEES NOT PAID